

***KITO ELECTRIC CHAIN HOIST***  
***ER2***

Smooth & Ergonomic Operation

Reliable Safety

Enhanced Durability

Easier Maintenance

Environmentally Friendly

# Dual speed inverter hoist provided as standard\*



## Contents

4	ER2 OUTLINE
4	SMOOTH & ERGONOMIC OPERATION
5	RELIABLE SAFETY
6	ENHANCED DURABILITY
6	EASIER MAINTENANCE
7	ENVIRONMENTALLY FRIENDLY
8	ER2 ELECTRIC CHAIN HOIST
9	ER2 ELECTRIC CHAIN HOIST LINEUP
9	TROLLEYS
10	LIFTING & TRAVERSING SPEED
10	PRODUCT CODE
11	CHAIN CONTAINERS
11	PRODUCT CONFIGURATIONS
12	LIFTING MOTOR RATINGS
13	HOIST CLASSIFICATIONS
14	ER2 Dual Speed <small>inverter</small> With Hook Suspension
15	ER2 Dual Speed 500V <small>pole change</small> With Hook Suspension
16	ER2M Dual Lifting <small>inverter</small> - Single Traversing Speed With Motorized Trolley
17	ER2M Dual Lifting <small>pole change</small> - Single Traversing Speed 500V With Motorized Trolley
18	ER2M Dual Lifting <small>inverter</small> - Dual Traversing Speed <small>inverter</small> With Motorized Trolley
19	ER2M Dual Lifting <small>pole change</small> - Dual Traversing Speed 500V <small>pole change</small> With Motorized Trolley
20	ER2SG Dual Speed <small>inverter</small> With Geared Trolley
21	ER2SG Dual Speed 500V <small>pole change</small> With Geared Trolley
22	ER2SP Dual Speed <small>inverter</small> With Plain Trolley
23	ER2SP Dual Speed 500V <small>pole change</small> With Plain Trolley
24	ER2 Single Speed With Hook Suspension
25	ER2M Single Lifting - Single Traversing Speed With Motorized Trolley
26	ER2SG Single Speed With Geared Trolley
27	ER2SP Single Speed With Plain Trolley
28	CDER2 Cylindrical Control Dual/Single Speed with Hook Suspension
29	ER2 Large Capacity With Hook Suspension
30	ER2M Large Capacity With Motorized Trolley
31	ER2SG Large Capacity With Geared Trolley
32	TWER2M Twin Hook
33	SHER2M Ultra Low Headroom
34	Options / Hook Dimensions
35	Applications

\*Except for specific voltage

## KITO ELECTRIC CHAIN HOIST **ER2**

The new KITO electric chain hoist ER2 has been released as a product that further builds upon KITO's previous ER series. Seeking improved ease of use and work efficiency, an inverter has been provided as standard in a dual speed hoist and trolley. The dual speed inverter delivers smoother movement than ever, reducing load swing.

To ensure safety, KITO utilizes a double safety mechanism consisting of an originally developed friction clutch and upper-lower limit switch. Uniquely-designed push button control on the basis of ergonomics, enhanced durability of load chain, improved ease of maintenance as well as support for the environment achieve higher safety and working efficiency. These products, therefore, provide long-period stable operation, which is essential for improving production efficiency. Due to further improved durability, the increased product service life and reduced running costs have resulted in minimizing the lifetime cost.

KITO electric chain hoists have sought the industry's top level of safety, durability and ease of maintenance, and to continue as highly trusted products selected around the world, the evolution of KITO electric chain hoists continues.

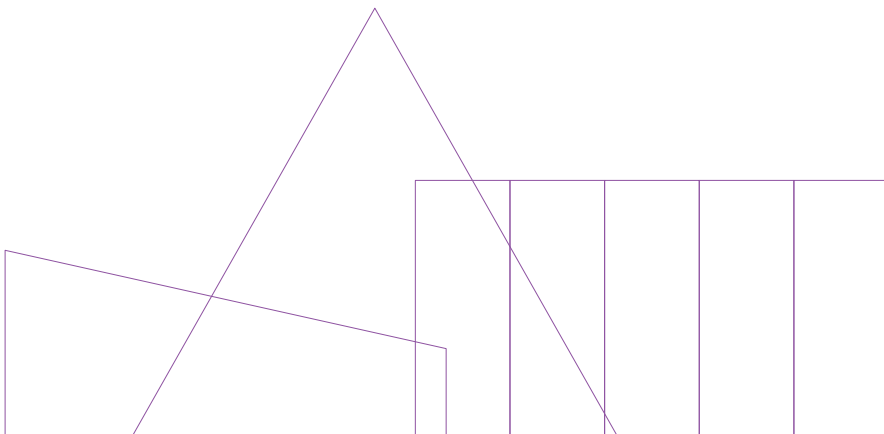

# Compact Body

## Light weight

The compact aluminum die-cast body has exceptional rigidity as well as, high dust-protection and water-protection. It has a simple structure with a small number of parts. Fine-tuned profile of the load chain link benefits loss of the hoist body weight compared to the previous ER.

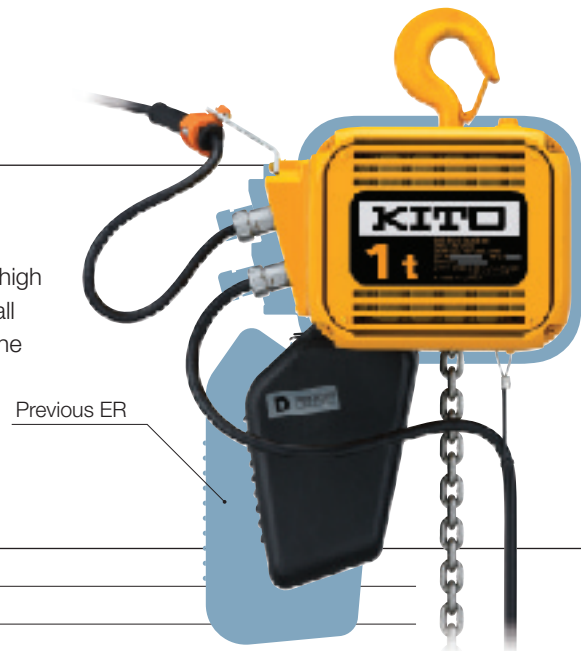

# ER2 Outline

Rated capacity:	Single speed – 125 kg to 20 t Dual speed – 125 kg to 5 t
Voltage:	220-230 V 50/60Hz 380-415 V 50 Hz 380-440 V 60 Hz 500 V 50 Hz (pole change for dual speed) (460 V 60 Hz for specific regions)
Control voltage:	24 V (110 V for specific regions)
Duty rating:	Single speed – 60% ED (60 min.) Dual speed – 40/20% ED (30/10 min.)
Classification:	M4, M5 (ISO); 1 Am, 2m (FEM); H4 (ASME)
Motor insulation:	Class B for 220-230-50/60 and 500-50 (460-60) Class F for 380-415-50 and 380-440-60
Enclosure:	Hoist body – IP55, Push button control - IP 65
Suspension varieties:	Hook, manual trolley, motorized trolley
Operating temperature:	-20 to 40 °C (-4 to 104 °F)
Operating humidity:	85%RH or less

# Smooth & Ergonomic Operation

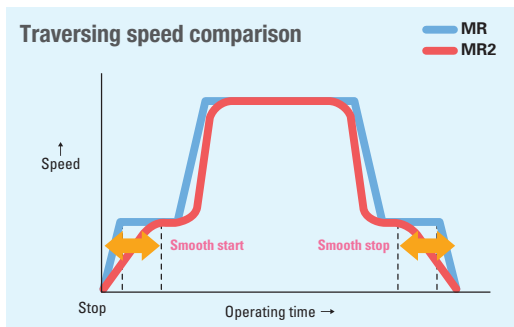
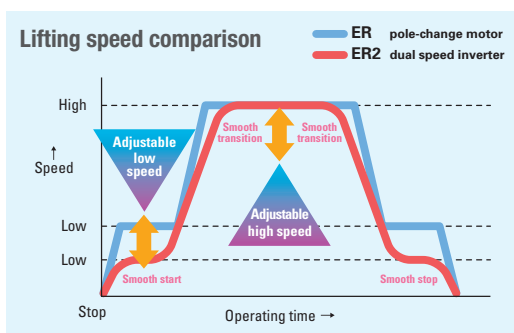

## Inverter

### smooth transitional speed

The dual speed inverter delivers smoother movement than the pole change motor, reducing load swing. The high to low speed ratio can be set to a large value. This results in smooth starts, improved low speed stops, and improved positioning accuracy. The standard speed ratio is 6:1 adjustable up to 12:1\* for lifting and 10:1\* for traversing.

ER2/MR2 inverter unit is well-customized for lifting/traversing applications including exclusive software with optimum control and is also provided with measures against impact and heat which were verified through long run tests.

\*For a speed ratio other than the standard, please make a request at the time of placing an order.

Accelerating and decelerating time in addition to speed are adjustable for dual speed inverter trolley.

## Push button control **original design**

The push button control is designed in an ergonomic shape that is operator friendly. Seeking ease of operation and universal design, KITO's original push button control was designed and manufactured based on trial and error repeated many times, in particular, upgrading prototypes and evaluation from an enduser point of view especially with respect to unit strength.

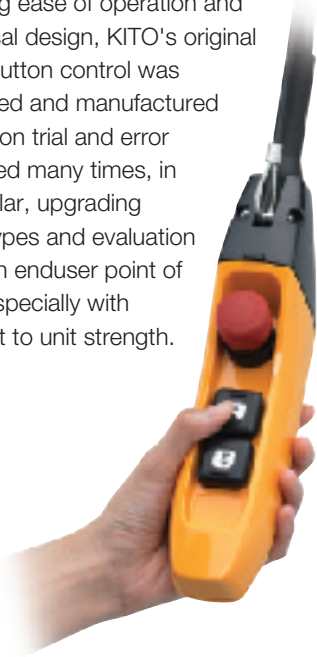

Contoured to comfortably fit into your hand. The button has a light operating sensation which responds to fine adjustments in pressure. The pressing stroke is short. The operator, therefore, will not become fatigued after long-periods of operation.



Back lug for firm grip

As for a crane fabrication with a motorized end truck, a control box is available if necessary.

Resistant to the collisions and shocks that may occur during work, KITO's original push button control can be used in various environments, thus supporting efficient work.



## Load sheave **reduced vibration**

Increasing the number of load sheave pockets helps relieve vibrations produced by the revolving polygonal sheave on the hoist's body and load chain.



# Reliable Safety

## Friction clutch & upper-lower limit switch **double safety**

Maintaining safety is the most important task for lifting equipment, and is essential for stable operation. To ensure safety, KITO utilizes a double safety mechanism consisting of an originally developed friction clutch and upper-lower limit switch.

The friction clutch is an emergency overload protection device that idles the motor when subjected to an excessive load over the rated capacity. Friction clutch performance is not easily compromised with changes in the surrounding temperature. In the case of irregular loading, this operates in advance to prevent the hoist body or load chain from being damaged.



In the event that a load is lifted or lowered excessively, the limit switch stops the motor, preventing hoist or load chain damage. (Not regular use)



## Thermal protector

To prevent the motor from burning out due to excessive usage, a standard thermal protector is installed in the motor.

## Electromagnetic brake **fail-safe connection**

Connected in series to a motor circuit, a current-driven electromagnetic brake does not release unless the motor is energized. This concurrent drive increases safety of the circuit compared to separate circuits for the motor and the brake.

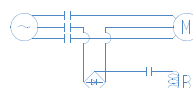

## Emergency stop

The emergency stop, provided as standard, allows the motor power to be disconnected in an emergency without cutting off the main power supply.

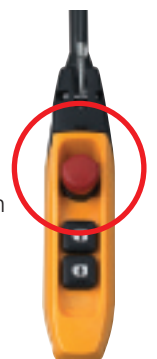



# Enhanced Durability

## High end duty rating

The ER2 achieves M5(ISO)/2m(FEM) class (refer to section of "Hoist Classifications"), with a duty cycle of 60% ED. Supporting use in the most demanding environments and conditions, this long service life hoist is a heavy-duty product which is also applicable to high frequency or long lift operations.

The gearbox is lubricated in an oil bath. As a result of this, wear and tear has been improved and cooling has also been enhanced at the same time.

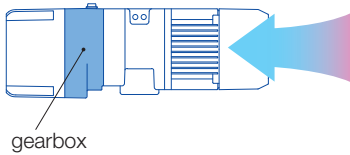

## Unique motor frame fins & fan cover

A unique fan-cooled motor with motor frame fins and a fan cover have been configured into a purpose built design. This design produces a much quieter motor unit as well as enhanced fan cooling capabilities.



## Load chain **super strength**

KITO's world class original super-strength nickel-plated load chain certified by German Institute, uses unique technology to greatly increase resistance to fatigue and wear.



Load chain wear comparison

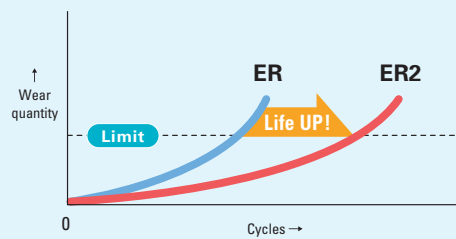

At KITO, testing is continuously being carried out regarding the load chain fatigue, wear, tensile strength, and environment. KITO takes pride in manufacturing load chains that have strength, durability and accuracy for utilization in the product. **ER2 chains are not compatible with that of the previous ER hoist series due to a difference of their chain profile.**

# Easier Maintenance

## Connecting shaft & cover belt

The connecting shaft that was previously attached inside the body is now mounted on the outside of the ER2. This allows a top hook or suspender to be attached or removed with ease.

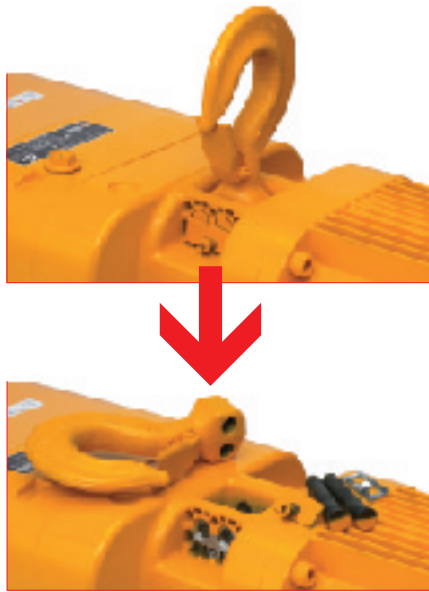

The electric parts and equipment are contained inside the controller cover. Therefore, inspection and parts replacement can be accomplished easily. The controller cover is connected to the hoist body using a cover belt so that maintenance can be carried out more easily.



## CH (counter hour) meter

As a standard feature, the hoist's total on-time and the number of lowering starts are shown on the LCD of the CH meter. This enables the user to carry out maintenance based upon the frequency of use. By maintaining a history of the CH meter data, the inspection periods and replacement periods for gear oil, contactors, brakes and load chains can be efficiently controlled, allowing the equipment to be used with confidence.



Dual speed



Single speed

# Environmentally Friendly

## No hazardous substances

As an environmental measure, several environmentally hazardous substances specified by KITO, including 6 European RoHS directive substances, are not used.

## Energy saving

Further, an energy-savings can be made due to reduction in rated current draw compared to the previous ER.

## Lower noise

The utilization of the inverter, 4-pole motor as well as the electromagnetic brake, reduces the noise during operation and braking.

# ER2 Electric Chain Hoist

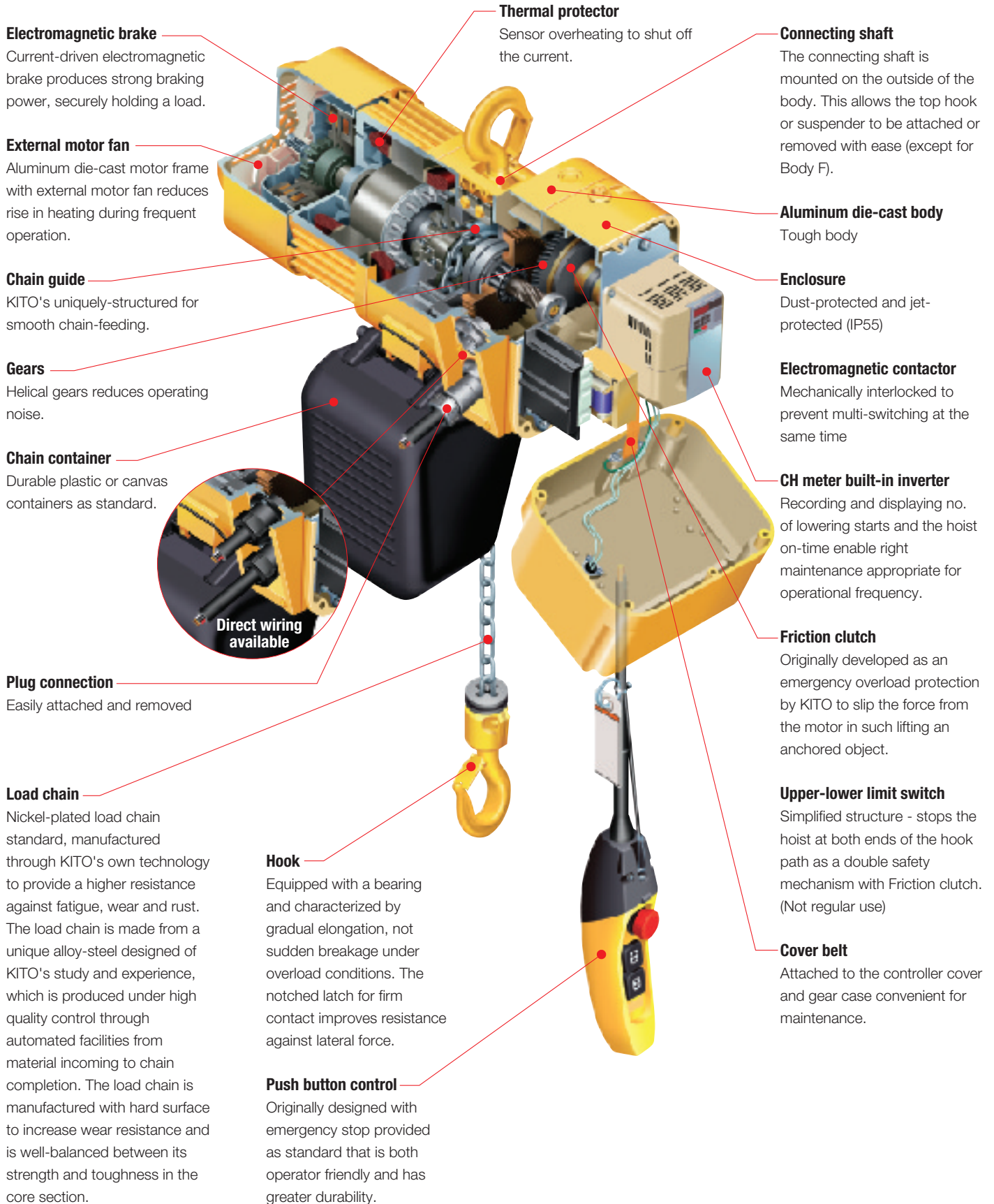



# ER2 Electric Chain Hoist Lineup

Type	Lifting speed		Capacity ( t )													
			125kg	250kg	500kg	1	1.5	2	2.5	3	5	Large capacity				
												7.5	10	15	20	
Hook suspension ER2	Single	Low			•	•		•								
		Standard		•	•	•	•	•	•	•	•		•	•	•	
		High	•	•												
	Dual inverter	Low			•	•		•								
		Standard		•	•	•	•	•	•	•	•					
		High	•	•												
Trolley suspension Motorized trolley ER2M Plain Trolley ER2SP (up to 5t) Geared Trolley ER2SG	Single	Low			•	•		•					•			
		Standard		•	•	•	•	•	•	•	•	•	•	•	•	
		High	•	•												
	Dual inverter	Low			•	•		•								
		Standard		•	•	•	•	•	•	•	•					
		High	•	•												

KITO will not be held liable for any malfunction, lack of performance or accident if the product is being used in conjunction with any other equipment. If the product is to be used for unintended purposes, please confirm with your dealer in advance.

## Trolleys

### Motorized Trolley MR2

Bearing built-in side rollers provide smooth running through the minimum radius curve and excellent traversing performance with preventive derailment.

#### Features

- Simple gear box construction
- Improved balance due to a lighter weight geared motor
- Speed variations
  - Single Low Speed
  - Single Standard Speed
  - Dual Speed

### Plain & Geared Trolley

- Designed to provide smooth and easy traversing.
- Lugs provide protection from striking damage against rail stoppers, and from falling off the rail.
- Wheel flanges also prevent derailment.

### Plain Trolley TSP

Designed for light load manual applications (125kg to 5t)

### Geared Trolley TSG

Designed for precise positioning and traversing by using hand chain (125kg to 20t)

#### Motorized Trolley MR2



125kg to 20t

#### Plain Trolley TSP



125kg to 3t



5t

#### Geared Trolley TSG

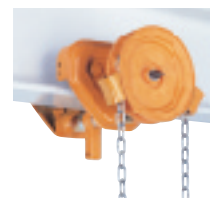

125kg to 3t

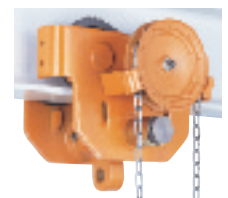

5t to 20t

# Lifting & Traversing Speed

## Lifting Speed

(m/min)

Capacity (t)	Single Speed						Dual Speed					
	50 Hz			60 Hz			50/60 Hz*			500 V		
	Low	Standard	High	Low	Standard	High	Low	Standard	High	Low	Standard	High
125kg			14.1			16.9			1.4 to 16.6			14.2/3.5
250kg		9.1	13.4		10.9	16.1		0.9 to 10.8	1.3 to 15.7		7.2/1.8	
500kg	3.8	7.3		4.6	8.8		0.4 to 4.5	0.7 to 8.5		3.6/0.9	7.1/1.8	
1	3.5	7.1		4.2	8.5		0.3 to 4.2	0.7 to 8.2		3.5/0.9	7.2/7.1	
1.5		4.5			5.4			0.4 to 5.3			4.8/1.2	
2	3.7	7.0		4.4	8.4		0.4 to 4.3	0.7 to 8.2		3.7/0.9	6.9/1.6	
2.5		5.7			6.8			0.6 to 6.6			5.5/1.3	
3		4.4			5.3			0.4 to 5.2			4.4/1.0	
5		2.9			3.5			0.3 to 3.3			2.8/0.6	
7.5		1.9			2.3							
10	1.4	2.9		1.7	3.5							
15		1.9			2.3							
20		1.4			1.7							

Note: The speed ratio of inverter hoists is preset to 6:1 in KITO factory.

## Traversing Speed

(m/min)

Capacity (t)	Single Speed				Dual Speed	
	50 Hz		60 Hz		50/60 Hz*	500 V
	Low	Standard	Low	Standard	Standard	Standard
125kg to 5	10	20	12	24	2.4 to 24	20/10
7.5 to 20	10		12			

Note: The speed ratio of inverter trolleys is preset to 6:1 in KITO factory.

# Product Code

Type

**ER2M010IS-IS**

ER2

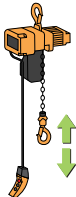

ER2M (ER2+MR2)

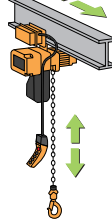

ER2SG (ER2+TSG)

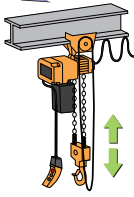

ER2SP (ER2+TSP)

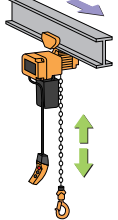

**Capacity**

Code	Capacity
001	125 kg
003	250 kg
005	500 kg
010	1 t
015	1.5 t
020	2 t
025	2.5 t
030	3 t
050	5 t
075	7.5 t
100	10 t
150	15 t
200	20 t

**Lifting speed**

Code	Lifting speed
S	single, standard
L	single, low
H	single, high
IS	inverter dual, standard
IL	inverter dual, low
IH	inverter dual, high
SD	dual, standard
LD	dual, low
HD	dual, high

**Traversing speed**

Code	Traversing speed
S	single, standard
L	single, low
IS	inverter dual, standard
SD	dual, standard

Ex. for ER2M010IS-IS, the electric chain hoist bears "ER2-010IS" as a product code and the motorized trolley "MR2-010IS".

# Chain Containers

## Type of containers

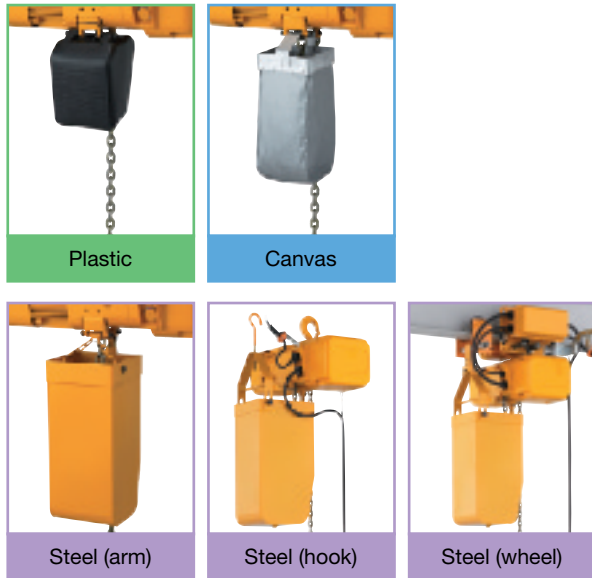

Product code	Body	≤4m	4.1 ≤6m	6.1 ≤8m	8.1 ≤9m	9.1 ≤12m	12.1 ≤15m	15.1 ≤18m	18.1m<
ER2-001H/IH	B								
ER2-003S/IS									
ER2-003H/IH	C								
ER2-005S/IS									
ER2-010L/IL	D								
ER2-010S/IS									
ER2-015S/IS	E								
ER2-020L/IL									
ER2-020S/IS	F								
ER2-025S/IS									
ER2-030S/IS	E								
ER2-050S/IS	F								
ER2-075S									
ER2-100L									
ER2-100S									
ER2-150S									
ER2-200S									

Containers are installed differently depending on the types of the products or lift.  
The steel containers may not cover the standard curve radii depending on their installation conditions.

# Product Configurations

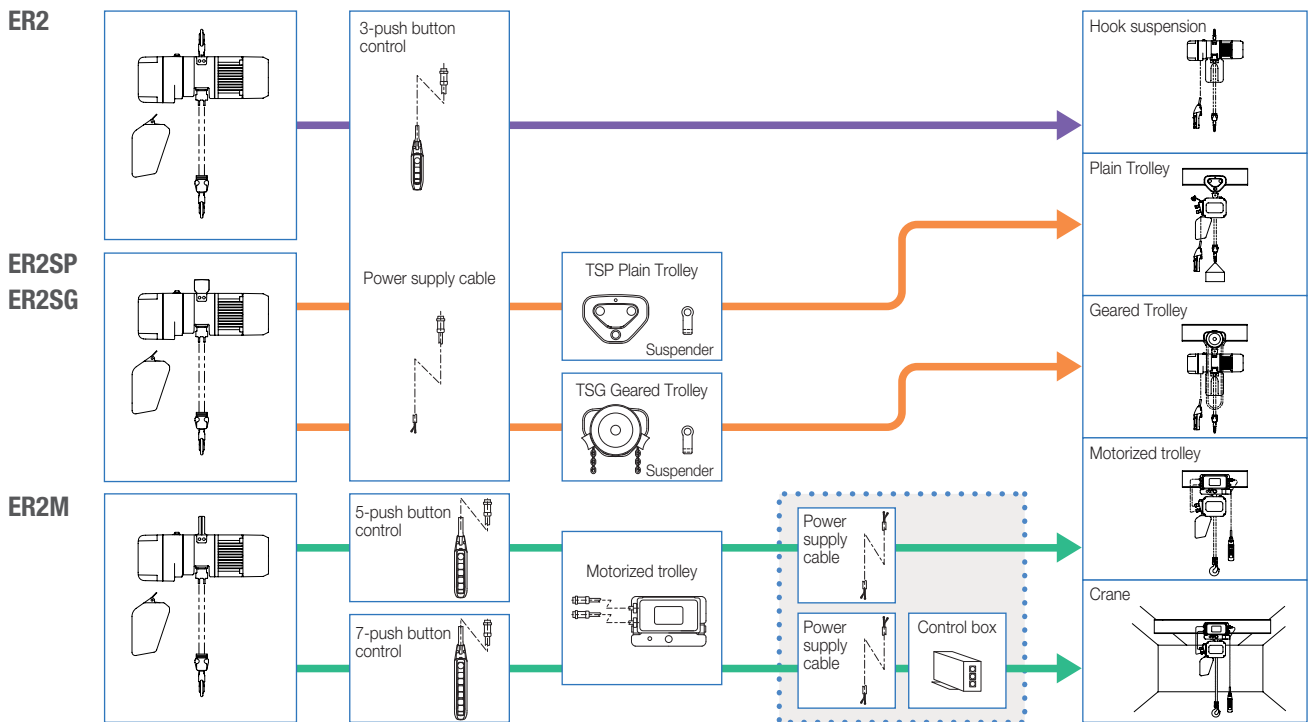

The following types of the hoist are configured differently from the above: Large capacities (7.5t or more), ER2SG/SP for crane, TWER2M and SHER2M

# Lifting Motor Ratings

## Short Time Rating

This rating indicates how long the hoist can be operated continuously on the below cycle, assuming continued operation for a short time span.

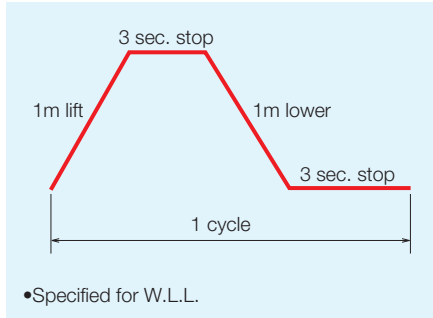

- Single Speed: 60min
- Dual Speed: 30/10min

## Intermittent Rating (Percent ED) Max. Number of Starts Per Hour

This rating indicates the ED percent (ratio of motor ON-to-OFF time) and max. number of starts per hour (how many times the motor is started up in one hour)

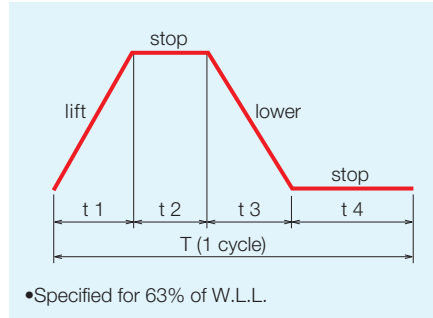

for a hoist operated continuously on the below cycle, assuming continued operation or repeated starting over a long time span.

In the case of single speed:

$$\%ED = \frac{\text{Motor ON time ( } t_1+t_3 \text{ )}}{1 \text{ cycle ( } T \text{ )}} \times 100$$

$$T = 1 \text{ cycle ( } t_1+t_2+t_3+t_4 \text{ )}$$

(Within 10 minutes)

%ED and max. number of starts per hour

- Single Speed: 60%ED, 360 starts/hr
- Dual Speed: 40/20 %ED, 240/120 starts/hr



# Hoist Classifications

## ISO/JIS

State of loading		Total duration of use (h)						
		200	400	800	1600	3200	6300	12500
Light	Mechanisms subjected very rarely to the maximum load and, normally, to light loads	–	–	M1	M2	M3	M4	M5
Moderate	Mechanisms subjected fairly frequently to the maximum load but, normally, to rather moderate loads	–	M1	M2	M3	M4	M5	M6
Heavy	Mechanisms subjected frequently to the maximum load and, normally, to loads of heavy magnitude	M1	M2	M3	M4	M5	M6	–
Very heavy	Mechanisms subjected regularly to the maximum load	M2	M3	M4	M5	M6	–	–

This classification refers to ISO 4301-1 and applies to the mechanical components including gears and bearings except for consumable parts.

## ASME HST

Hoist duty class	Typical areas of application	Operation time ratings at $K=0.65$			
		Uniformly distributed work periods		Infrequent work periods	
		Max. on time, min/ hr	Max. No. starts/ hr	Max. on time from cold start, min	Max. No. of starts
H2	Light machine shop fabricating, service, and maintenance; loads and utilization randomly distributed; rated loads infrequently handled	7.6 (12.5%)	75	15	100
H3	General machine shop fabricating, assembly, storage, and warehousing; loads and utilization randomly distributed	15 (25%)	150	30	200
H4	High volume handling in steel warehouses, machine shops, fabricating plants and mills, and foundries; manual or automatic cycling operations in heat treating and plating; loads at or near rated load frequently handled	30 (50%)	300	30	300

The grade symbols are identical to those of ASME HST-1M. (Performance standard for Electric Chain Hoist)

## FEM Relation between ISO-and FEM-Denominations

1 D <sub>m</sub>	1 C <sub>m</sub>	1 B <sub>m</sub>	1 A <sub>m</sub>	2 m	3 m	4 m	5 m
M 1	M 2	M 3	M 4	M 5	M 6	M 7	M 8

Load spectrum	Cubic mean value	Class of operation time									
		V 0.06	V 0.02	V 0.25	V 0.5	V 1	V 2	V 3	V 4	V 5	
		T 0	T 1	T 2	T 3	T 4	T 5	T 6	T 7	T 8	
		Average operating time per day in hours									
		≤0.12	≤0.25	≤0.5	≤1	≤2	≤4	≤8	≤16	>16	
1 L1	$K \leq 0.50$	–	–	1 D <sub>m</sub>	1 C <sub>m</sub>	1 B <sub>m</sub>	1 A <sub>m</sub>	2 m	3 m	4 m	
2 L2	$0.50 < K \leq 0.63$	–	1 D <sub>m</sub>	1 C <sub>m</sub>	1 B <sub>m</sub>	1 A <sub>m</sub>	2 m	3 m	4 m	5 m	
3 L3	$0.63 < K \leq 0.80$	1 D <sub>m</sub>	1 C <sub>m</sub>	1 B <sub>m</sub>	1 A <sub>m</sub>	2 m	3 m	4 m	5 m	–	
4 L4	$0.80 < K \leq 1.00$	1 C <sub>m</sub>	1 B <sub>m</sub>	1 A <sub>m</sub>	2 m	3 m	4 m	5 m	–	–	

Class of operating time		Average operating time per day (in hours)	Calculated total operating time (in hours)
V0.06	T0	≤0.12	200
V0.12	T1	≤0.25	400
V0.25	T2	≤0.5	800
V0.5	T3	≤1	1,600
V1	T4	≤2	3,200
V2	T5	≤4	6,300
V3	T6	≤8	12,500
V4	T7	≤16	25,000
V5	T8	>16	50,000

The grade symbols are identical to those of FEM 9.511. (Rules for Design of Serial Lifting Equipment: Classification of Mechanisms)

# ER2 Dual Speed inverter

With Hook Suspension

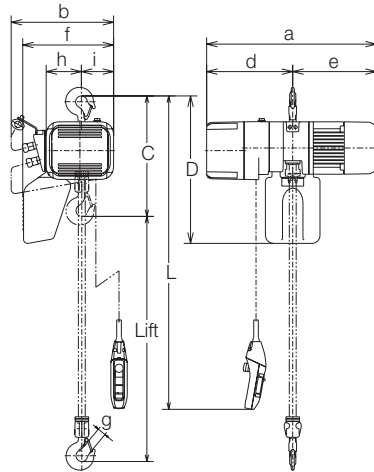

- Five meters of power supply cable as standard accompanies.
- Optional length of lift, push button cord and power supply cable besides standard is available on your request.
- Extending the load chain is prohibited with additional links.
- Steel chain containers are available as option as shown in Section of "Chain Containers" if your lift is more than capacity of the standard container volume.

## Specifications

Capacity (t)	Product Code	Hoist Body	Standard Lift (m)	Push Button Cord L (m)	Lifting Motor		Lifting Speed (m/min)*			Load Chain		Classification ISO/FEM/ASME	Test Load (t)	Net Weight (kg)	Additional Weight per 1m Lift (kg)
					Output (kW)	Rating (%ED)	50/60Hz		Diameter (mm)	Chain Falls					
							High	Low							
125kg	ER2-001IH	B			0.56		Preset	16.6	2.8	4.3	x 1		156kg	27	0.42
	Adjustable							1.4							
250kg	ER2-003IS				0.9		Preset	10.8	1.8				313kg	36	
	Adjustable							0.9							
500kg	ER2-003IH	C			0.56		Preset	15.7	2.6	6	x 1	M5/2m/H4	625kg	32	0.81
	Adjustable							1.3							
1	ER2-005IL	D	3	2.5	0.9	40/20	Preset	4.5	0.8	7.7	x 1		1.25	45	1.33
	Adjustable							0.4							
1.5	ER2-010IS	E			1.8		Preset	8.5	1.4				1.88	72	
	Adjustable							0.7							
2	ER2-015IS	F			3.5		Preset	4.2	0.7	10.2	x 1		2.5	73	2.3
	Adjustable							0.3							
2.5	ER2-020IS				1.8		Preset	8.2	1.4				3.13	100	2.8
	Adjustable							0.7							
3	ER2-025IS	E			3.5		Preset	8.2	1.4				3.75	105	4.7
	Adjustable							0.7							
5	ER2-030IS	F			2.8		Preset	6.6	1.1	11.2	x 1	M4/1Am/H4	6.25	128	5.6
	Adjustable							0.6							
5	ER2-050IS				2.8		Preset	5.2	0.9	10.2	x 2		6.25	105	4.7
	Adjustable							0.4							
5	ER2-050IS				2.8		Preset	3.3	0.6	11.2	x 2		6.25	128	5.6
	Adjustable							0.3							

Note: The high speed is preset to the maximum speed in KITO factory. The speeds are adjustable between High and Low.

## Dimensions (mm)

Capacity (t)	Product Code	Headroom C	D	a	b	d	e	f	g	h	i
125kg	ER2-001IH	350	430	535	345	276	259	284	27	99	117
250kg	ER2-003IS										
250kg	ER2-003IH	370	490	568	348	300	271	283	27	113	106
500kg	ER2-005IS										
1	ER2-010IL	430	550	614	376	316	298	335	31	129	118
	ER2-010IS										
1.5	ER2-015IS	510	630	710	427	372	338	384.5	34	160.5	137.5
2	ER2-020IS	575									
2.5	ER2-025IS	590		767		411	356	39			
2.5	ER2-025IS	625	840	800	445	401	399	437.5		173.5	142.5
3	ER2-030IS	785	920	767	427	411	356	397	44	216	82
5	ER2-050IS	850									

# ER2 Dual Speed 500V pole change

With Hook Suspension

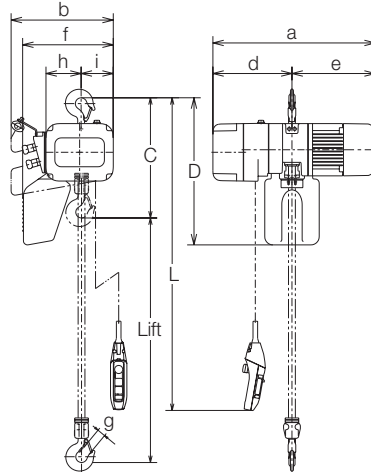

- Five meters of power supply cable as standard accompanies.
- Optional length of lift, push button cord and power supply cable besides standard is available on your request.
- Extending the load chain is prohibited with additional links.
- Steel chain containers are available as option as shown in Section of "Chain Containers" if your lift is more than capacity of the standard container volume.

## Specifications

Capacity (t)	Product Code	Hoist Body	Standard Lift (m)	Push Button Cord L (m)	Lifting Motor		Lifting Speed (m/min)	Load Chain		Classification ISO/FEM/ASME	Test Load (t)	Net Weight (kg)	Additional Weight per 1m Lift (kg)
					Output (kW)	Rating (%ED)		50Hz	Diameter (mm) x Chain Falls				
125kg	ER2-001HD	B					14.2/3.5	4.3 x 1			156kg	31	0.42
250kg	ER2-003SD						7.2/1.8				313kg		
500kg	ER2-005LD	C					3.6/0.9	6 x 1	M5/2m/H4		625kg	39	0.81
	ER2-005SD						7.1/1.8				43		
1	ER2-010LD	D	3	2.5		40/20	3.5/0.9	7.7 x 1			1.25	56	1.33
	ER2-010SD						7.2/1.7					58	
1.5	ER2-015SD						4.8/1.2				1.88	74	
2	ER2-020LD	E					3.7/0.9	10.2 x 1			2.5	76	2.3
	ER2-020SD						6.9/1.6					97	
2.5	ER2-025SD	F					5.5/1.3	11.2 x 1	M4/1Am/H4		3.13	108	2.8
3	ER2-030SD	E					4.4/1.0	10.2 x 2			3.75	113	4.7
5	ER2-050SD	F		2.8			2.8/0.6	11.2 x 2			6.25	134	5.6

## Dimensions (mm)

Capacity (t)	Product Code	Headroom C	D	a	b	d	e	f	g	h	i
125kg	ER2-001HD	350	430	478	321	219	259	260	27	99	93
250kg	ER2-003SD			513							
500kg	ER2-005LD	370	490	513	348	242	271	283	27	113	106
	ER2-005SD			533			291				
1	ER2-010LD	430	550	589	376	291	298	335	31	129	118
	ER2-010SD			615			324				
1.5	ER2-015SD	510		646	427	308	338	384.5	34		
2	ER2-020LD	575	630	646							
	ER2-020SD	590		737	347	390					
2.5	ER2-025SD	625	840	736	445	337	399	437.5		173.5	142.5
3	ER2-030SD	785	920	737	427	347	390	397	44	216	82
5	ER2-050SD	850		736	445	337	399	439	47	231.5	84.5

# ER2M Dual Lifting inverter - Single Traversing Speed

With Motorized Trolley

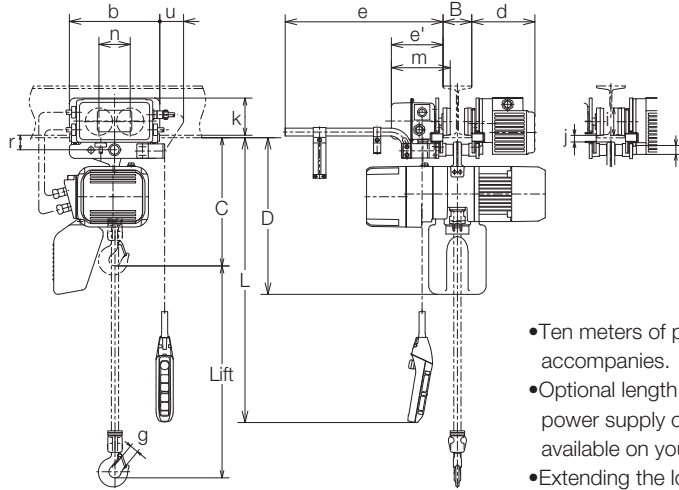

- Ten meters of power supply cable as standard accompanies.
- Optional length of lift, push button cord and power supply cable besides standard is available on your request.
- Extending the load chain is prohibited with additional links.
- Steel chain containers are available as option as shown in Section of "Chain Containers" if your lift is more than capacity of the standard container volume.

## Specifications

Capacity (t)	Product Code	ER2										MR2				Test Load (t)	Net Weight (kg)	Additional Weight per 1m Lift (kg)			
		Hoist Body	Standard Lift (m)	Push Button Cord L (m)	Lifting Motor		Lifting Speed (m/min)*		Load Chain		Classification ISO/FEM /ASME	Traversing Motor		Traversing Speed (m/min)					Flange Width B (mm)		Min. Radius Curve (mm)
					Output (kW)	Rating (%ED)	High	Low	Diameter (mm)	Chain Falls		Output (kW)	Rating (%ED)	50Hz	60Hz				Standard	Option W30 (305mm)	
125kg	ER2M001IH-S/L	B			0.56	Preset	16.6	2.8	4.3 x 1									156kg	58	0.42	
250kg	ER2M003IS-S/L					Adjustable	10.8	1.4													Preset
	ER2M003IH-S/L	Adjustable	10.8	1.8	Adjustable	15.7	0.9	7.7 x 1									1.25	75	1.33		
500kg	ER2M005IL-S/L	C			0.56	Preset	4.5													0.8	6 x 1
	ER2M005IS-S/L					Adjustable	4.5	0.4	Preset	8.5	1.4	7.7 x 1									
1	ER2M010IL-S/L	D	3	2.5	40/20	Preset	4.2	0.7	7.7 x 1												
	ER2M010IS-S/L					Adjustable	4.2	0.3				Preset	8.2	1.4	10.2 x 1						
1.5	ER2M015IS-S/L	E			1.8	Preset	5.3	0.9	10.2 x 1												
	ER2M020IL-S/L					Adjustable	5.3	0.4							Preset	4.3	0.7	10.2 x 1			
2	ER2M020IS-S/L	Adjustable	4.3	0.4	Preset	8.2	1.4	11.2 x 1	M4/1Am /H4								2.5				127
	2.5	ER2M025IS-S/L	F			3.5	Preset											6.6	1.1	11.2 x 1	
3		ER2M030IS-S/L					E			2.8	Adjustable	6.6	0.6	10.2 x 2							
	5	ER2M050IS-S/L	F			2.8					Preset	5.2	0.9							11.2 x 2	
ER2M050IS-S/L		Adjustable					5.2	0.4	Preset	3.3	0.6	11.2 x 2									
						Adjustable	3.3	0.3													

Note: The bracketed figures in Traversing Speed are low speed. The minimum radius curve may depend on flange width. For further information, contact the nearest KITO dealer. The high speed is preset to the maximum speed in KITO factory. The speeds are adjustable between High and Low.

## Dimensions (mm)

Capacity (t)	Product Code	Headroom C	D	b	d	e	e'	g	i	j	k	m	n	r	t	u
125kg	ER2M001IH-S/L	375	450													
250kg	ER2M003IS-S/L															
	ER2M003IH-S/L	435	550													
500kg	ER2M005IL-S/L															
	ER2M005IS-S/L	570	630	325	225	520	184		110	27	125	212	118	60	36	76
1	ER2M010IL-S/L															
	ER2M010IS-S/L	620	830	340	226	521	186		125	29	131	215	132	68	43	70
1.5	ER2M015IS-S/L															
	2	ER2M020IL-S/L	840	910	400	281	528	192		140	44	145	233	150	86	54
ER2M020IS-S/L																
2.5	ER2M025IS-S/L															
	3	ER2M030IS-S/L														
5		ER2M050IS-S/L														



# ER2M Dual Lifting pole change - Single Traversing Speed 500V

With Motorized Trolley

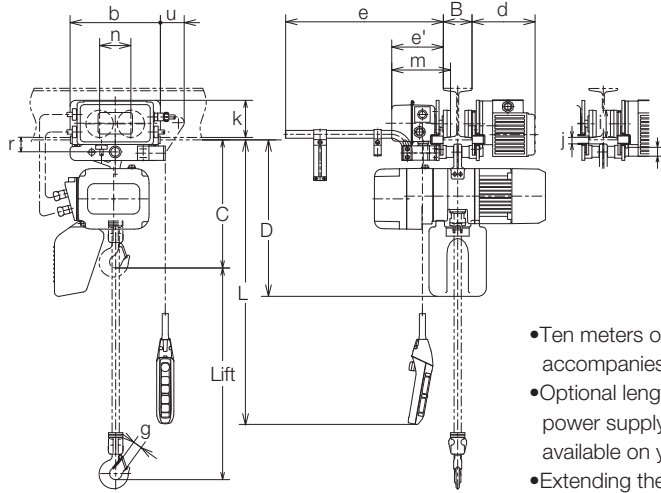

- Ten meters of power supply cable as standard accompanies.
- Optional length of lift, push button cord and power supply cable besides standard is available on your request.
- Extending the load chain is prohibited with additional links.
- Steel chain containers are available as option as shown in Section of "Chain Containers" if your lift is more than capacity of the standard container volume.

## Specifications

Capacity (t)	Product Code	Hoist Body	ER2							MR2					Test Load (t)	Net Weight (kg)	Additional Weight per 1m Lift (kg)			
			Standard Lift (m)	Push Button Cord L (m)	Lifting Motor		Lifting Speed (m/min)	Load Chain	Classification ISO/FEM /ASME	Traversing Motor		Traversing Speed (m/min)	Flange Width B (mm)					Min. Radius Curve (mm)		
					Output (kW)	Rating (%ED)				Output (kW)	Rating (%ED)		Standard	Option W30 (305mm)						
125kg	ER2M001HD-S/L	B			0.5/0.13	14.2/3.5	4.3 x 1											156kg	62	0.42
250kg	ER2M003SD-S/L					7.2/1.8												313kg		
500kg	ER2M005LD-S/L	C			0.9/0.23	3.6/0.9	6 x 1	M5/2m /H4				58 to 153	154 to 305					625kg	70	0.81
						ER2M005SD-S/L												7.1/1.8	74	
1	ER2M010LD-S/L	D	3	2.5	40/20	3.5/0.9	7.7 x 1		0.4	40	20 (10)			800				86	1.33	
	ER2M010SD-S/L					7.2/1.7												88		
1.5	ER2M015SD-S/L	E			1.8/0.45													1.88	112	
2	ER2M020LD-S/L	E				3.7/0.9	10.2 x 1					82 to 178						2.5	114	2.3
						ER2M020SD-S/L												6.9/1.6	135	
2.5	ER2M025SD-S/L	F			3.5/0.88	5.5/1.3	11.2 x 1	M4/1Am /H4						1000				3.13	156	2.8
3	ER2M030SD-S/L	E				4.4/1.0	10.2 x 2											100 to 178	3.75	
5	ER2M050SD-S/L	F		2.8		2.8/0.6	11.2 x 2		0.75					1800	6.25	204	5.6			

Note: The bracketed figures in Traversing Speed are low speed. The minimum radius curve may depend on flange width. For further information, contact the nearest KITO dealer.

## Dimensions (mm)

Capacity (t)	Product Code	Headroom C	D	b	d	e	e'	g	i	j	k	m	n	r	t	u
125kg	ER2M001HD-S/L	375	450													
250kg	ER2M003SD-S/L															
500kg	ER2M005LD-S/L	395	510	315	268	515	179		95	22	130	205	109	51	31	83
1	ER2M010LD-S/L	435	550													
1.5	ER2M015SD-S/L	505														
2	ER2M020LD-S/L	570	630	325	273	520	184		110	27	125	212	118	60	36	77
2.5	ER2M025SD-S/L	620	830	340	274	521	186		125	29	131	215	132	68	43	70
3	ER2M030SD-S/L	765	900													
5	ER2M050SD-S/L	840	910	400	281	528	192	47	140	44	145	233	150	86	54	56

# ER2M Dual Lifting inverter - Dual Traversing Speed inverter

With Motorized Trolley

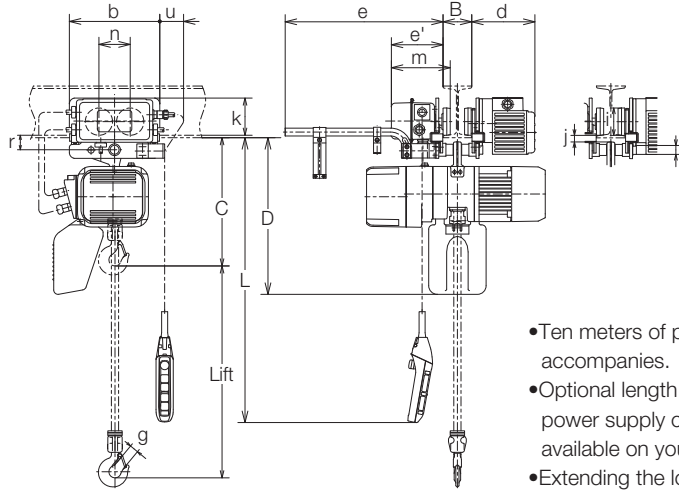

- Ten meters of power supply cable as standard accompanies.
- Optional length of lift, push button cord and power supply cable besides standard is available on your request.
- Extending the load chain is prohibited with additional links.
- Steel chain containers are available as option as shown in Section of "Chain Containers" if your lift is more than capacity of the standard container volume.

## Specifications

Capacity (t)	Product Code	Hoist Body	Standard Lift (m)	Push Button Cord L (m)	ER2						MR2						Test Load (t)	Net Weight (kg)	Additional Weight per 1m Lift (kg)	
					Lifting Motor		Lifting Speed (m/min)*		Load Chain	Classification ISO/FEM /ASME	Traversing Motor		Traversing Speed* (m/min)		Flange Width B (mm)					Min. Radius Curve (mm)
					Output (kW)	Rating (%ED)	50/60Hz High	50/60Hz Low			Output (kW)	Rating (%ED)	50/60Hz High	50/60Hz Low	Standard	Option W30 (305mm)				
125kg	ER2M001IH-IS	B			0.56	Preset	16.6	2.8	4.3 x 1								156kg	59	0.42	
250kg	ER2M003IS-IS					Adjustable	10.8	1.8												Preset
	ER2M003IH-IS	Adjustable	10.8	0.9	Preset	15.7	2.6	6 x 1	M5/2m /H4	0.4	27/13	Adjustable	24	2.4	82 to 178 / 179 to 305	1000	625kg	69	0.81	
500kg	ER2M005IL-IS	C			0.56	Preset	4.5													0.8
	ER2M005IS-IS					Adjustable	4.5	0.4	Preset	8.5	1.4	6 x 1	M5/2m /H4	0.4	27/13	Adjustable	24	2.4	82 to 178 / 179 to 305	1000
1	ER2M010IL-IS	D	3	2.5	0.9	Preset	4.2	0.7	7.7 x 1	M4/1Am /H4	0.75									
	ER2M010IS-IS					Adjustable	4.2	0.3				Preset	8.2	1.4	7.7 x 1	M4/1Am /H4	0.75			
1.5	ER2M015IS-IS				1.8	Preset	5.3	0.9	10.2 x 1											
	ER2M020IL-IS					Adjustable	5.3	0.4							Preset	4.3	0.7	10.2 x 1		
2	ER2M020IS-IS	E			1.8	Preset	4.3	0.7	10.2 x 1											
	ER2M020IS-IS					Adjustable	4.3	0.4										Preset	8.2	1.4
2.5	ER2M025IS-IS	F			3.5	Preset	6.6	1.1	11.2 x 1	M4/1Am /H4	0.75							3.13	151	2.8
	ER2M025IS-IS					Adjustable	6.6	0.6												
3	ER2M030IS-IS	E			2.8	Preset	5.2	0.9	10.2 x 2									3.75	155	4.7
	ER2M030IS-IS					Adjustable	5.2	0.4												
5	ER2M050IS-IS	F			2.8	Preset	3.3	0.6	11.2 x 2									6.25	200	5.6
	ER2M050IS-IS					Adjustable	3.3	0.3												

Note: The minimum radius curve may depend on flange width. For further information, contact the nearest KITO dealer.  
The high speed is preset to the maximum speed in KITO factory. The speeds are adjustable between High and Low.

## Dimensions (mm)

Capacity (t)	Product Code	Headroom C	D	b	d	e	e'	g	i	j	k	m	n	r	t	u
125kg	ER2M001IH-IS	375	450													
250kg	ER2M003IS-IS															
	ER2M003IH-IS	435	550						110	27	125	212	118	60	36	76
500kg	ER2M005IL-IS															
	ER2M005IS-IS	505														
1	ER2M010IL-IS															
	ER2M010IS-IS	570	630	325	225	520	184		110	27	125	212	118	60	36	76
1.5	ER2M015IS-IS															
	ER2M020IL-IS	620	830	340	226	521	186		125	29	131	215	132	68	43	70
2	ER2M020IS-IS															
	ER2M025IS-IS	765	900	340	226	521	186	44	125	29	131	215	132	68	43	70
2.5	ER2M025IS-IS															
	ER2M030IS-IS	840	910	400	281	528	192	47	140	44	145	233	150	86	54	56
3	ER2M030IS-IS															
	ER2M050IS-IS	840	910	400	281	528	192	47	140	44	145	233	150	86	54	56
5	ER2M050IS-IS															
	ER2M050IS-IS	840	910	400	281	528	192	47	140	44	145	233	150	86	54	56

# ER2M Dual Lifting pole change - Dual Traversing Speed **500V** pole change

With Motorized Trolley

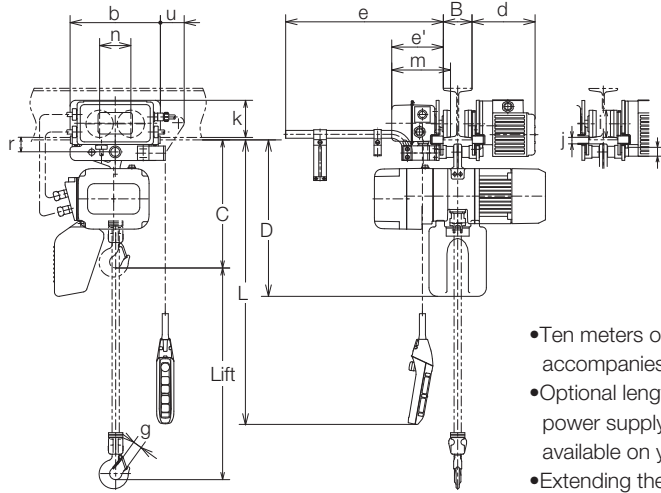

- Ten meters of power supply cable as standard accompanies.
- Optional length of lift, push button cord and power supply cable besides standard is available on your request.
- Extending the load chain is prohibited with additional links.
- Steel chain containers are available as option as shown in Section of "Chain Containers" if your lift is more than capacity of the standard container volume.

## Specifications

Capacity (t)	Product Code	Hoist Body	ER2							MR2					Test Load (t)	Net Weight (kg)	Additional Weight per 1m Lift (kg)		
			Standard Lift (m)	Push Button Cord L (m)	Lifting Motor		Lifting Speed (m/min)	Load Chain	Classification ISO/FEM /ASME	Traversing Motor		Traversing Speed (m/min)	Flange Width B (mm)					Min. Radius Curve (mm)	
					Output (kW)	Rating (%ED)				Output (kW)	Rating (%ED)		Standard	Option W30 (305mm)					
125kg	ER2M001HD-SD	B			0.5/0.13	14.2/3.5	4.3 x 1										156kg	66	0.42
250kg	ER2M003SD-SD					7.2/1.8											313kg		
500kg	ER2M005LD-SD	C			0.9/0.23	3.6/0.9	6 x 1	M5/2m /H4				58 to 153	154 to 305				625kg	74	0.81
						ER2M005SD-SD											7.1/1.8	77	
1	ER2M010LD-SD	D	3	2.5	40/20	3.5/0.9	7.7 x 1		0.32/0.08					800			89	1.33	
						ER2M010SD-SD											7.2/1.7		92
1.5	ER2M015SD-SD	E			1.8/0.45	4.8/1.2											1.88	116	
2	ER2M020LD-SD	E				3.7/0.9	10.2 x 1					82 to 178	179 to 305				2.5	117	2.3
						ER2M020SD-SD											6.9/1.6	138	
2.5	ER2M025SD-SD	F			3.5/0.88	5.5/1.3	11.2 x 1	M4/1Am /H4									3.13	159	2.8
3	ER2M030SD-SD	E				4.4/1.0	10.2 x 2										0.64/0.16	3.75	
5	ER2M050SD-SD	F			2.8/0.6	11.2 x 2						100 to 178		1800	6.25	208	5.6		

Note: The minimum radius curve may depend on flange width. For further information, contact the nearest KITO dealer.

## Dimensions (mm)

Capacity (t)	Product Code	Headroom C	D	b	d	e	e'	g	i	j	k	m	n	r	t	u
125kg	ER2M001HD-SD	375	450													
250kg	ER2M003SD-SD															
500kg	ER2M005LD-SD	395	510	315	268	515	179	27	95	22	130	205	109	51	31	83
1	ER2M010LD-SD	435	550					31								
1.5	ER2M015SD-SD	505						34								
2	ER2M020LD-SD	570	630	325	273	520	184	39	110	27	125	212	118	60	36	77
		ER2M020SD-SD														
2.5	ER2M025SD-SD	620	830	340	274	521	186		125	29	131	215	132	68	43	70
3	ER2M030SD-SD	765	900													
5	ER2M050SD-SD	840	910	400	281	528	192	47	140	44	145	233	150	86	54	56

# ER2SG Dual Speed inverter

With Geared Trolley

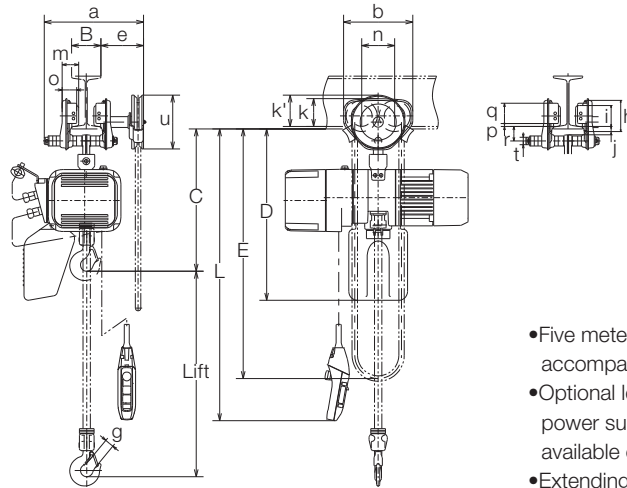

- Five meters of power supply cable as standard accompanies.
- Optional length of lift, push button cord and power supply cable besides standard is available on your request.
- Extending the load chain is prohibited with additional links.
- Steel chain containers are available as option as shown in Section of "Chain Containers" if your lift is more than capacity of the standard container volume.

## Specifications

Capacity (t)	Product Code	ER2										TSG				Test Load (t)	Net Weight (kg)	Additional Weight per 1m Lift (kg)		
		Hoist Body	Standard Lift (m)	Push Button Cord L (m)	Lifting Motor		Lifting Speed (m/min)*		Load Chain		Classification ISO/FEM /ASME	Folded Hand Chain Length E (m)	Flange Width B (mm)						Min. Radius Curve (mm)	
					Output (kW)	Rating (%ED)	50/60Hz		Diameter (mm)	Chain Falls			Standard	Option						
							High	Low						W20 (203mm)	W30 (305mm)					
125kg	ER2SG001IH	B			0.56		Preset	16.6	2.8	4.3 x 1								156kg	40	1.4
250kg	ER2SG003IS						Adjustable	10.8	1.4											
	ER2SG003IH	Adjustable	15.7	2.6	Preset	4.5	0.8	7.7 x 1	2.7	82 to 153	154 to 305	1500	2.5	90	3.2					
500kg	ER2SG005IL	C			0.56		Adjustable									4.5	0.4	10.2 x 1		
	ER2SG005IS						Adjustable	8.5	1.4	Preset	8.2	1.4	M4/1Am /H4							
1	ER2SG010IL	D	3	2.5		40/20	Adjustable	4.2	0.7	11.2 x 1										
	ER2SG010IS						Adjustable	8.2	0.7				Preset	5.3	0.9	10.2 x 2				
1.5	ER2SG015IS	E			1.8		Adjustable	5.3	0.4	11.2 x 2										
	2						ER2SG020IL	Adjustable	4.3							0.7	Preset			
ER2SG020IS		Adjustable	8.2	0.7	Preset	6.6	1.1	1700												
2.5	ER2SG025IS	F			3.5		Adjustable													6.6
	3						ER2SG030IS	Adjustable	5.2	0.4	Preset	3.3	0.6	11.2 x 2						
5		ER2SG050IS	F		2.8			Adjustable	3.3	0.3	11.2 x 2									

Note: The high speed is preset to the maximum speed in KITO factory. The speeds are adjustable between High and Low.

## Dimensions (mm)

Capacity (t)	Product Code	Headroom C	D	a	b	e	g	h	i	j	k	k'	m	n	o	p	q	r	t	u
125kg	ER2SG001IH	415	490																	
250kg	ER2SG003IS																			
500kg	ER2SG005IL	435	550	345	236	152		106	71	28	95	107	56	112	50		69	50	25	
	ER2SG005IS																			
1	ER2SG010IL	470	590													10				183
	ER2SG010IS																			
1.5	ER2SG015IS	570																		
	2																			
ER2SG020IS		650	39																	
2.5	ER2SG025IS	680	890	398	324	157		148	100	36	134	115	80	152	74		102	68	36	
3	ER2SG030IS	780	910																	44
5	ER2SG050IS	840		401	400	156	47	169	118	46	144	131	81	178	70		104	88	54	





# ER2SP Dual Speed inverter

With Plain Trolley

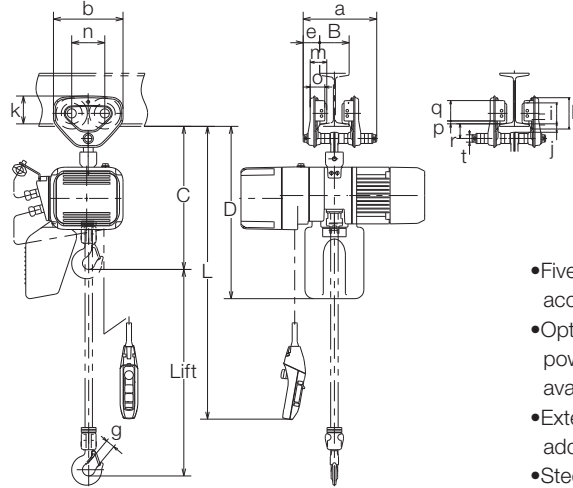

- Five meters of power supply cable as standard accompanies.
- Optional length of lift, push button cord and power supply cable besides standard is available on your request.
- Extending the load chain is prohibited with additional links.
- Steel chain containers are available as option as shown in Section of "Chain Containers" if your lift is more than capacity of the standard container volume.
- The hoist direction to a beam for 3 t or 5 t is different 90 degrees.

## Specifications

Capacity (t)	Product Code	ER2										TSP			Test Load (t)	Net Weight (kg)	Additional Weight per 1m Lift (kg)	
		Hoist Body	Standard Lift (m)	Push Button Cord L (m)	Lifting Motor		Lifting Speed (m/min)*		Load Chain	Classification ISO/FEM /ASME	Flange Width B (mm)			Min. Radius Curve (mm)				
					Output (kW)	Rating (%ED)	50/60Hz				Diameter (mm) x Chain Falls	Standard	Option					
							High	Low					W20 (203mm)					W30 (305mm)
125kg	ER2SP001IH	B			0.56	40/20	Preset	16.6	2.8	4.3 x 1	M5/2m /H4	50 to 102	103 to 203	1100	156kg	32	0.42	
250kg	ER2SP003IS						Adjustable	1.4	1.8									
	ER2SP003IH	Preset	10.8	0.9	6 x 1	M5/2m /H4	50 to 102	103 to 203	1100	313kg	41	0.81						
ER2SP005IL		C	0.56	Preset									15.7	2.6				
500kg	ER2SP005IS	D		3	2.5	0.9	40/20	Preset	4.5	0.8	7.7 x 1	M4/1Am /H4	82 to 153	154 to 305	1700	625kg	37	41
	1		ER2SP010IS					Adjustable	1.3	0.4								
1.5		ER2SP015IS	E			1.8	40/20	Preset	8.5	1.4	10.2 x 1	M4/1Am /H4	82 to 153	154 to 305	1700	1.25	53	1.33
	Adjustable							0.7	0.3									
2	ER2SP020IS	F			3.5	40/20	Preset	4.2	0.7	11.2 x 1	M4/1Am /H4	100 to 178	179 to 305	2300	6.25	178	5.6	
							Adjustable	1.4	0.7									
2.5	ER2SP025IS	E			2.8	40/20	Preset	5.3	0.9	10.2 x 2	M4/1Am /H4	100 to 178	179 to 305	2300	6.25	178	5.6	
							Adjustable	0.4	0.4									
3	ER2SP030IS	F			3.5	40/20	Preset	4.3	0.7	11.2 x 2	M4/1Am /H4	100 to 178	179 to 305	2300	6.25	178	5.6	
							Adjustable	0.4	0.4									
5	ER2SP050IS	F			2.8	40/20	Preset	8.2	1.4	11.2 x 2	M4/1Am /H4	100 to 178	179 to 305	2300	6.25	178	5.6	
							Adjustable	0.7	0.3									

Note: The high speed is preset to the maximum speed in KITO factory. The speeds are adjustable between High and Low.

## Dimensions (mm)

Capacity (t)	Product Code	Headroom C	D	a	b	e	g	h	i	j	k	m	n	o	p	q	r	t
125kg	ER2SP001IH	395	470															
250kg	ER2SP003IS			204	182	46	27	82	60	21	76	47.5	84	42			54	38
	ER2SP003IH																	
500kg	ER2SP005IL	415	530															
	ER2SP005IS																	
1	ER2SP010IL	470	590	249	236	56	31	106	71	28	95	56	112	50	10	69	50	25
	ER2SP010IS																	
1.5	ER2SP015IS	570					34											
2	ER2SP020IL	635	690	300	280	69		127	85	34	112	71	131	63		83	62	32
	ER2SP020IS						39											
2.5	ER2SP025IS	680	890	320	324	79		148	100	36	134	80	152	74		102	68	36
3	ER2SP030IS	780	910				44											
5	ER2SP050IS	840		297	400	53	47	169	118	46	144	81	178	70		104	88	54

# ER2SP Dual Speed 500V pole change

With Plain Trolley

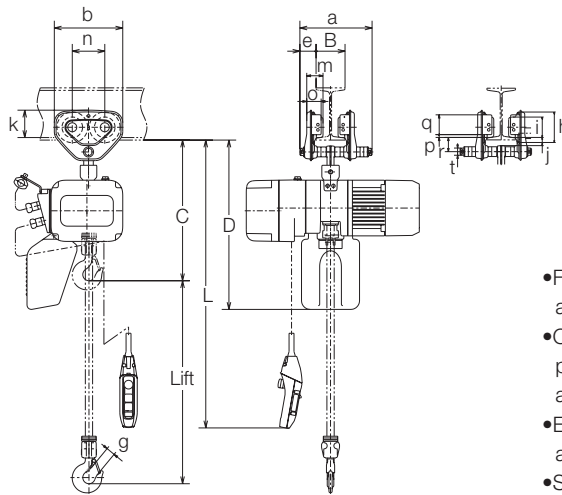

- Five meters of power supply cable as standard accompanies.
- Optional length of lift, push button cord and power supply cable besides standard is available on your request.
- Extending the load chain is prohibited with additional links.
- Steel chain containers are available as option as shown in Section of "Chain Containers" if your lift is more than capacity of the standard container volume.
- The hoist direction to a beam for 3 t or 5 t is different 90 degrees.

## Specifications

Capacity (t)	Product Code	ER2								TSP				Test Load (t)	Net Weight (kg)	Additional Weight per 1m Lift (kg)						
		Hoist Body	Standard Lift (m)	Push Button Cord L (m)	Lifting Motor		Lifting Speed (m/min)	Load Chain	Classification ISO/FEM /ASME	Flange Width B (mm)			Min. Radius Curve (mm)									
					Output (kW)	Rating (%ED)				Standard	Option											
125kg	ER2SP001HD	B			0.5/0.13	14.2/3.5	4.3 x 1													156kg	36	0.42
250kg	ER2SP003SD																			313kg		
500kg	ER2SP005LD	C			0.9/0.23	3.6/0.9	6 x 1	M5/2m /H4												625kg	44	0.81
	ER2SP005SD																			48		
1	ER2SP010LD	D	3	2.5	0.9/0.23	3.5/0.9	7.7 x 1													64	1.33	
	ER2SP010SD																			7.2/1.7		66
1.5	ER2SP015SD				1.8/0.45	4.8/1.2														1.88	87	
2	ER2SP020LD	E				3.7/0.9	10.2 x 1													89	2.3	
	ER2SP020SD																			6.9/1.6		111
2.5	ER2SP025SD	F			3.5/0.88	5.5/1.3	11.2 x 1	M4/1Am /H4												3.13	132	2.8
3	ER2SP030SD	E																		4.4/1.0	10.2 x 2	
5	ER2SP050SD	F		2.8		2.8/0.6	11.2 x 2													6.25	184	5.6

## Dimensions (mm)

Capacity (t)	Product Code	Headroom C	D	a	b	e	g	h	i	j	k	m	n	o	p	q	r	t
125kg	ER2SP001HD	395	470															
250kg	ER2SP003SD			204	182	46	27	82	60	21	76	47.5	84	42			54	38
500kg	ER2SP005LD	415	530															
	ER2SP005SD																	
1	ER2SP010LD	470	590	249	236	56	31	106	71	28	95	56	112	50	10	69	50	25
	ER2SP010SD																	
1.5	ER2SP015SD	570					34											
	ER2SP020LD	635	690	300	280	69		127	85	34	122	71	131	63		83	62	32
ER2SP020SD	650						39											
2.5	ER2SP025SD	680	890															
3	ER2SP030SD	780	910	320	324	79		148	100	36	134	80	152	74		102	68	36
				44														
5	ER2SP050SD	840		297	400	53	47	169	118	46	144	81	178	70		104	88	54

# ER2 Single Speed

With Hook Suspension

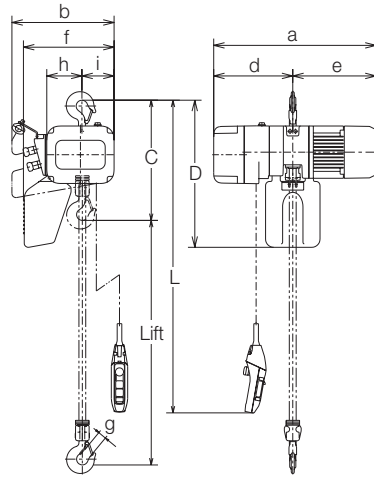

- Five meters of power supply cable as standard accompanies.
- Optional length of lift, push button cord and power supply cable besides standard is available on your request.
- Extending the load chain is prohibited with additional links.
- Steel chain containers are available as option as shown in Section of "Chain Containers" if your lift is more than capacity of the standard container volume.

## Specifications

Capacity (t)	Product Code	Hoist Body	Standard Lift (m)	Push Button Cord L (m)	Lifting Motor		Lifting Speed (m/min)		Load Chain		Classification ISO/FEM/ASME	Test Load (t)	Net Weight (kg)	Additional Weight per 1m Lift (kg)
					Output (kW)	Rating (%ED)	50Hz	60Hz	Diameter (mm)	Chain Falls				
125kg	ER2-001H	B			0.56		14.1	16.9	4.3	x 1		156kg	27	0.42
250kg	ER2-003S						9.1	10.9				313kg		
		ER2-003H	0.9	13.4	16.1	6	x 1	M5/2m/H4	625kg	33	0.81			
500kg	ER2-005L	C		0.56	3.8				4.6	37				
	ER2-005S				0.9	7.3	8.8	7.7	x 1	1.25	47	1.33		
1	ER2-010L	D	3	2.5	60	3.5	4.2			1.88	72			
	ER2-010S					7.1	8.5	2.5	73	2.3				
1.5	ER2-015S	E				4.5	5.4	10.2	x 1		M4/1Am/H4	3.13	104	2.8
2	ER2-020L					3.7	4.4			2.5		91		
		ER2-020S	7.0	8.4	3.75	107								
2.5	ER2-025S	F		3.5			5.7	6.8	11.2	x 1	6.25	132	5.6	
3	ER2-030S	E		2.8		4.4	5.3	10.2	x 2					
5	ER2-050S	F				2.9	3.5	11.2	x 2					

## Dimensions (mm)

Capacity (t)	Product Code	Headroom C	D	a	b	d	e	f	g	h	i
125kg	ER2-001H	350	430	478	321	219	259	260	27	99	93
250kg	ER2-003S			510		268					
		ER2-003H	513	348	242	271	283	27	113	106	
500kg	ER2-005L	370	490	510			268				
	ER2-005S			589	376	291	298	335	31	129	118
1	ER2-010L	430	550	598			307				
	ER2-010S			646		308	338		34		
1.5	ER2-015S	510	630	703	427		347	356	39	160.5	137.5
2	ER2-020L	575		736	445	337	399	437.5		173.5	142.5
		ER2-020S	590	703	427	347	356	397	44	216	82
2.5	ER2-025S	625	840	736	445	337	399	439	47	231.5	84.5
3	ER2-030S	785	920	703	427	347	356	397	44	216	82
5	ER2-050S	850		736	445	337	399	439	47	231.5	84.5

# ER2M Single Lifting - Single Traversing Speed

With Motorized Trolley

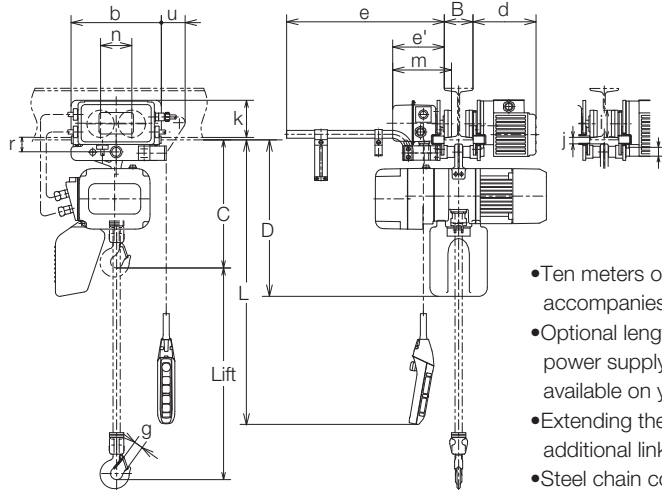

- Ten meters of power supply cable as standard accompanies.
- Optional length of lift, push button cord and power supply cable besides standard is available on your request.
- Extending the load chain is prohibited with additional links.
- Steel chain containers are available as option as shown in Section of "Chain Containers" if your lift is more than capacity of the standard container volume.
- Single Lifting - Dual Traversing is also available.

## Specifications

Capacity (t)	Product Code	ER2										MR2				Test Load (t)	Net Weight (kg)	Additional Weight per 1m Lift (kg)		
		Hoist Body	Standard Lift (m)	Push Button Cord L (m)	Lifting Motor		Lifting Speed (m/min)		Load Chain Diameter x Chain Falls	Classification ISO/FEM /ASME	Traversing Motor		Traversing Speed (m/min)		Flange Width B (mm)				Min. Radius Curve (mm)	
					Output (kW)	Rating (%ED)	50Hz	60Hz			Output (kW)	Rating (%ED)	50Hz	60Hz	Standard					Option W30 (305mm)
125kg	ER2M001H-S/L	B			0.56		14.1	16.9	4.3 x 1								156kg	58	0.42	
250kg	ER2M003S-S/L						9.1	10.9												625kg
250kg	ER2M003H-S/L	C			0.9		13.4	16.1	6 x 1	M5/2m /H4				58 to 153	154 to 305	800	64	0.81		
500kg	ER2M005L-S/L						3.8	4.6											7.7 x 1	
500kg	ER2M005S-S/L	D	3	2.5	0.9	60	7.3	8.8	7.7 x 1		0.4	40	20	24	(10)	(12)	1.25	77		1.33
1	ER2M010L-S/L						7.1	8.5										1.88	110	
1	ER2M010S-S/L	E			1.8		4.5	5.4	10.2 x 1					82 to 178			2.5			111
1.5	ER2M015S-S/L						3.7	4.4										1000		
2	ER2M020L-S/L	F			3.5		7.0	8.4	11.2 x 1	M4/1Am /H4				179 to 305			3.13		152	2.8
2	ER2M020S-S/L						5.7	6.8										1800	6.25	
2.5	ER2M025S-S/L	E			3.5		4.4	5.3	10.2 x 2				100 to 178			3.75	155			4.7
3	ER2M030S-S/L						4.4	5.3									1800	6.25	202	
5	ER2M050S-S/L	F			2.8		2.9	3.5	11.2 x 2											

Note: The bracketed figures in Traversing Speed are low speed. The minimum radius curve may depend on flange width. For further information, contact the nearest KITO dealer.

## Dimensions (mm)

Capacity (t)	Product Code	Headroom C	D	b	d	e	e'	g	i	j	k	m	n	r	t	u
125kg	ER2M001H-S/L	375	450													
250kg	ER2M003S-S/L															
250kg	ER2M003H-S/L	395	510	315	220	515	179	27	95	22	130	205	109	51	31	83
500kg	ER2M005L-S/L															
500kg	ER2M005S-S/L	435	550													
1	ER2M010L-S/L															
1	ER2M010S-S/L	505														
1.5	ER2M015S-S/L															
2	ER2M020L-S/L	570	630	325	225	520	184	39	110	27	125	212	118	60	36	76
2	ER2M020S-S/L	585														
2.5	ER2M025S-S/L	620	830	340	226	521	186		125	29	131	215	132	68	43	70
3	ER2M030S-S/L	765	900													
5	ER2M050S-S/L	840	910	400	281	528	192	47	140	44	145	233	150	86	54	56

# ER2SG Single Speed

With Geared Trolley

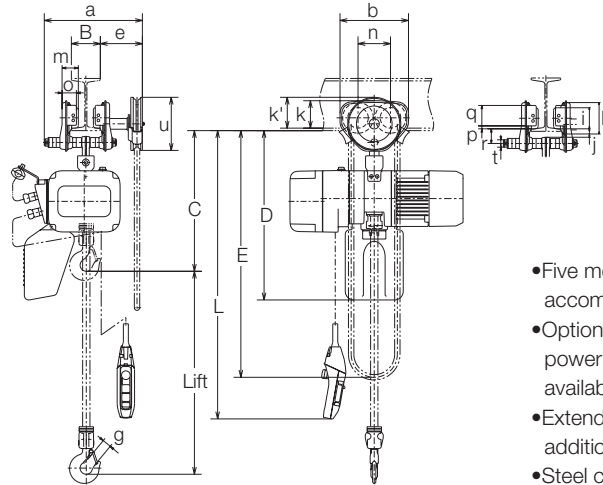

- Five meters of power supply cable as standard accompanies.
- Optional length of lift, push button cord and power supply cable besides standard is available on your request.
- Extending the load chain is prohibited with additional links.
- Steel chain containers are available as option as shown in Section of "Chain Containers" if your lift is more than capacity of the standard container volume.

## Specifications

Capacity (t)	Product Code	ER2										TSG				Test Load (t)	Net Weight (kg)	Additional Weight per 1m Lift (kg)						
		Hoist Body	Standard Lift (m)	Push Button Cord L (m)	Lifting Motor		Lifting Speed (m/min)		Load Chain	Classification ISO/FEM /ASME	Folded Hand Chain Length E (m)	Flange Width B (mm)		Min. Radius Curve (mm)										
					Output (kW)	Rating (%ED)	50Hz	60Hz				Diameter (mm)	Chain Falls		Standard				Option					
125kg	ER2SG001H	B			0.56		14.1	16.9	4.3 x 1												156kg	40	1.4	
250kg	ER2SG003S						9.1	10.9																313kg
250kg	ER2SG003H	C			0.9		13.4	16.1	6 x 1	M5/2m /H4		58 to 127	128 to 203	204 to 305	1300						625kg	46	1.7	
500kg	ER2SG005L						3.8	4.6																50
500kg	ER2SG005S	D	3	2.5	0.9	60	7.3	8.8	7.7 x 1		2.7											59	2.3	
1	ER2SG010L						3.5	4.2																1.25
1	ER2SG010S	E			1.8		7.1	8.5	10.2 x 1			82 to 153		154 to 305	1500							1.25	66	
1.5	ER2SG015S						4.5	5.4																1.88
2	ER2SG020L	F			3.5		3.7	4.4	11.2 x 1	M4/1Am /H4					1700							3.13	132	3.7
2	ER2SG020S						7.0	8.4																
2.5	ER2SG025S	E			3.5		5.7	6.8	10.2 x 2													3.75	134	5.6
3	ER2SG030S						4.4	5.3																
5	ER2SG050S	F			2.8		2.9	3.5	11.2 x 2		3.2	100 to 178		179 to 305	2300							6.25	188	6.5

## Dimensions (mm)

Capacity (t)	Product Code	Headroom C	D	a	b	e	g	h	i	j	k	k'	m	n	o	p	q	r	t	u			
125kg	ER2SG001H	415	490																				
250kg	ER2SG003S																						
250kg	ER2SG003H	435	550	345	236	152		106	71	28	95	107	56	112	50		69	50	25				
500kg	ER2SG005L																						
500kg	ER2SG005S	470	590																				
1	ER2SG010L																						
1	ER2SG010S	570																					
1.5	ER2SG015S																						
2	ER2SG020L	635	690	385	280	154		127	85	34	112	109	71	131	63		83	62	32				
2	ER2SG020S	650																					
2.5	ER2SG025S	680	890	398	324	157		148	100	36	134	115	80	152	74		102	68	36				
3	ER2SG030S	780																					
5	ER2SG050S	840	910	401	400	156		169	118	46	144	131	81	178	70		104	88	54				
5	ER2SG050S	47																					



# ER2SP Single Speed

With Plain Trolley

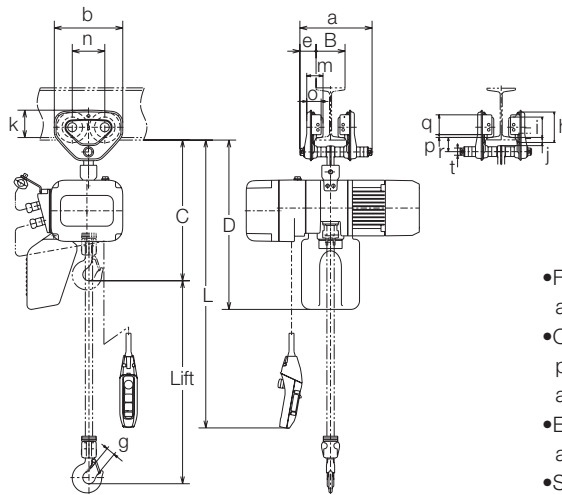

- Five meters of power supply cable as standard accompanies.
- Optional length of lift, push button cord and power supply cable besides standard is available on your request.
- Extending the load chain is prohibited with additional links.
- Steel chain containers are available as option as shown in Section of "Chain Containers" if your lift is more than capacity of the standard container volume.
- The hoist direction to a beam for 3 t or 5 t is different 90 degrees.

## Specifications

Capacity (t)	Product Code	ER2								TSP				Test Load (t)	Net Weight (kg)	Additional Weight per 1m Lift (kg)						
		Hoist Body	Standard Lift (m)	Push Button Cord L (m)	Lifting Motor		Lifting Speed (m/min)		Load Chain	Classification ISO/FEM/ASME	Flange Width B (mm)						Min. Radius Curve (mm)					
					Output (kW)	Rating (%ED)	50Hz	60Hz			Diameter	Chain	Standard					Option				
125kg	ER2SP001H	B			0.56		14.1	16.9	4.3 x 1											156kg	32	0.42
250kg	ER2SP003S						9.1	10.9												50 to 102		
	ER2SP003H	0.9	13.4	16.1	M5/2m/H4																	
500kg	ER2SP005L	C																		0.56		
	ER2SP005S				0.9	7.3	8.8	M5/2m/H4														
1	ER2SP010L	D	3	2.5		60	3.5													4.2		
	ER2SP010S						0.9	7.1	8.5	M5/2m/H4												
1.5	ER2SP015S	E			1.8		4.5	5.4	10.2 x 1													
2	ER2SP020L						3.7	4.4		82 to 153	154 to 305	1500	2.5	86	M4/1AmVH4							
	ER2SP020S	7.0	8.4	1700																		
2.5	ER2SP025S	F									3.5				5.7	6.8	11.2 x 1					
3	ER2SP030S	E		4.4	5.3	M4/1AmVH4																
5	ER2SP050S	F	2.8		3.5						2.9	3.5					11.2 x 2					
						3.5		2.9	3.5		11.2 x 2											

## Dimensions (mm)

Capacity (t)	Product Code	Headroom C	D	a	b	e	g	h	i	j	k	m	n	o	p	q	r	t
125kg	ER2SP001H	395	470															
250kg	ER2SP003S																	
	ER2SP003H			204	182	46	27	82	60	21	76	47.5	84	42		54	38	22
500kg	ER2SP005L	415	530															
	ER2SP005S																	
1	ER2SP010L	470	590	249	236	56	31	106	71	28	95	56	112	50	10	69	50	25
	ER2SP010S																	
1.5	ER2SP015S	570						34										
2	ER2SP020L	635	690	300	280	69		127	85	34	112	71	131	63		83	62	32
	ER2SP020S	650										39						
2.5	ER2SP025S	680	890	320	324	79		148	100	36	134	80	152	74		102	68	36
3	ER2SP030S	780										44						
5	ER2SP050S	840	910	297	400	53	47	169	118	46	144	81	178	70		104	88	54

# CDER2 Cylindrical Control Dual/Single Speed

with Hook Suspension



Dual Speed

Single Speed

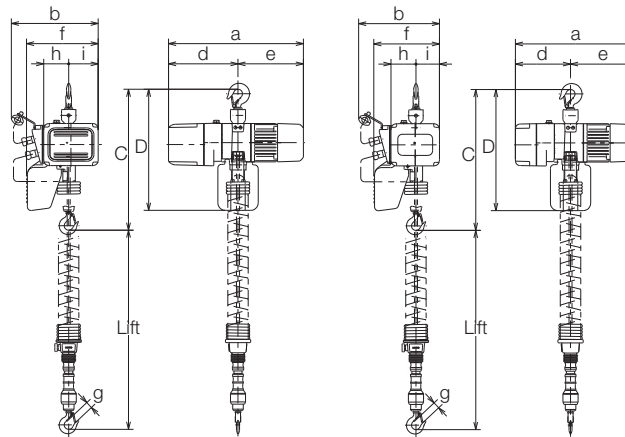

Dual Speed

Single Speed

- Five meters of power supply cable as standard accompanies.
- Length of lift, push button cord and power supply cable is standard only available.
- Extending the load chain is prohibited with additional links.
- Plastic chain container is provided only.

## Specifications

Capacity (t)	Product Code	Hoist Body	Standard Lift (m)	Lifting Motor		Lifting Speed (m/min)*		Load Chain		Classification ISO/FEM/ASME	Test Load (kg)	Net Weight (kg)	Additional Weight per 1m Lift (kg)
				Output (kW)	Rating (%ED)	50/60Hz		Diameter (mm)	Chain Falls				
						High	Low						
Dual	125kg ER2C001IH	B	1.8	0.56	40/20	Preset	2.8	4.3	x 1	M5/2m/H4	156	29	0.42
						Adjustable	1.4						
	250kg ER2C003IS					Preset	1.8						
						Adjustable	0.9						

Note: The high speed is preset to the maximum speed in KITO factory. The speeds are adjustable between High and Low.

## 500V

Capacity (t)	Product Code	Hoist Body	Standard Lift (m)	Lifting Motor		Lifting Speed (m/min)	Load Chain		Classification ISO/FEM/ASME	Test Load (kg)	Net Weight (kg)	Additional Weight per 1m Lift (kg)
				Output (kW)	Rating (%ED)	50Hz	Diameter (mm)	Chain Falls				
Dual	125kg ER2C001HD	B	1.8	0.5/0.13	40/20	14.2/3.5	4.3	x 1	M5/2m/H4	156	34	0.42
	250kg ER2C003SD					7.2/1.8						

Capacity (t)	Product Code	Hoist Body	Standard Lift (m)	Lifting Motor		Lifting Speed (m/min)		Load Chain		Classification ISO/FEM/ASME	Test Load (kg)	Net Weight (kg)	Additional Weight per 1m Lift (kg)
				Output (kW)	Rating (%ED)	50Hz	60Hz	Diameter (mm)	Chain Falls				
Single	125kg ER2C001H	B	1.8	0.56	60	14.1	16.9	4.3	x 1	M5/2m/H4	156	30	0.42
	250kg ER2C003S					9.1	10.9						

## Dimensions (mm)

Capacity (t)	Product Code	Headroom C	D	a	b	d	e	f	g	h	i
125kg	ER2C001IH	1065	490	535	345	276	259	284	27	99	117
250kg	ER2C003IS			478	321	219					
125kg	ER2C001HD	1065	490	478	321	219	259	260	27	99	93
250kg	ER2C003SD										
125kg	ER2C001H	1065	490	478	321	219	259	260	27	99	93
250kg	ER2C003S										

# ER2 Large Capacity

With Hook Suspension

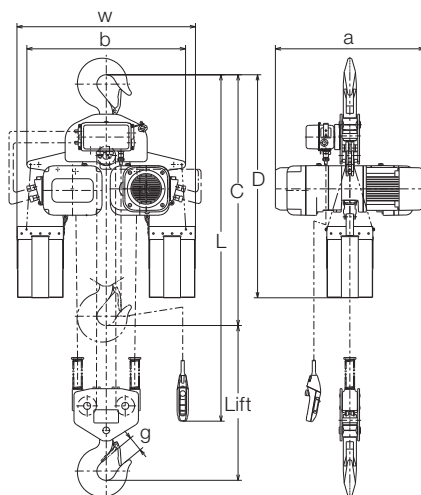
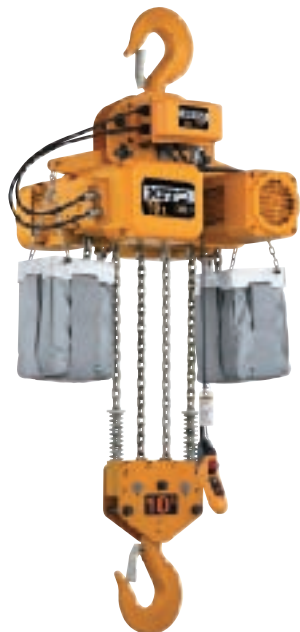

- Ten meters of power supply cable as standard accompanies.
- Optional length of lift, push button cord and power supply cable besides standard is available on your request.
- Extending the load chain is prohibited with additional links.
- Steel chain containers are available as option as shown in Section of "Chain Containers" if your lift is more than capacity of the standard container volume.

## Specifications

Capacity (t)	Product Code	Hoist Body	Standard Lift (m)	Push Button Cord L (m)	Lifting Motor		Lifting Speed (m/min)		Load Chain Diameter (mm) x Chain Falls	Classification ISO/FEM/ASME	Test Load (t)	Net Weight (kg)	Additional Weight per 1m Lift (kg)
					Output (kW)	Rating (%ED)	50Hz	60Hz					
10	ER2-100S			3.4			2.9	3.5	11.2 x 4		12.5	303	11
15	ER2-150S	F	3	3.7	3.5x2	60	1.9	2.3	11.2 x 6	M4/1Am/H4	18.8	404	17
20	ER2-200S						1.4	1.7					

## Dimensions (mm)

Capacity (t)	Product Code	Headroom C	D	a	b	w	g
10	ER2-100S	1370	1210		849	956	80
15	ER2-150S	1595	1520	798	1022	1129	86
20	ER2-200S	1710	1600		1198	1305	102

# ER2M Large Capacity

With Motorized Trolley

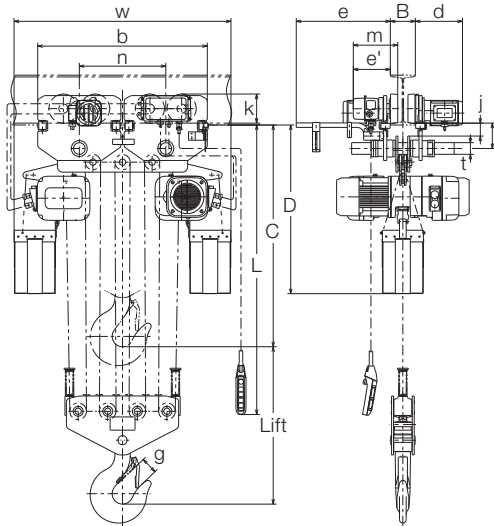

- Ten meters of power supply cable as standard accompanies.
- Optional length of lift, push button cord and power supply cable besides standard is available on your request.
- Extending the load chain is prohibited with additional links.
- Steel chain containers are available as option as shown in Section of "Chain Containers" if your lift is more than capacity of the standard container volume.

## Specifications

Capacity (t)	Product Code	ER2										MR2				Test Load (t)	Net Weight (kg)	Additional Weight per 1m Lift (kg)		
		Hoist Body	Standard Lift (m)	Push Button Cord L (m)	Lifting Motor		Lifting Speed (m/min)		Load Chain Diameter (mm) x Chain Falls	Classification ISO/FEM /ASME	Traversing Motor		Traversing Speed (m/min)		Flange Width B (mm)				Min. Radius Curve (mm)	
					Output (kW)	Rating (%ED)	50Hz	60Hz			Output (kW)	Rating (%ED)	50Hz	60Hz						Standard
7.5	ER2M075S-L				3.5	60	1.9	2.3	11.2 x 3	M4/1Am /H4	0.75	40	10	12	150 to 220	221 to 305	2500	9.4	283	8.4
10	ER2M100L-L	F	3	3.3			1.4	1.7	11.2 x 4									12.5	378	
	ER2M100S-L				2.9	3.5	11.2 x 6	399	11											
15	ER2M150S-L				3.5x2		1.9	2.3	11.2 x 6		0.75x2						∞	18.8	571	17
20	ER2M200S-L						1.4	1.7	11.2 x 8									25	628	22

Note: Trolley wheels for tapered I-beam are provided as standard. The wheels for flat flange beam are also available so make a request in advance if necessary. The minimum radius curve for 7.5t and 10t may depend on flange width. For further information, contact the nearest KITO dealer.

## Dimensions (mm)

Capacity (t)	Product Code	Headroom C	D	b	e	e'	g	j	k	m	n	r	t	w
7.5	ER2M075S-L	1165	1230	500	531	223	61	87	175	268	191	153	70	672
10	ER2M100L-L	1180	1210				80	77						
	ER2M100S-L		1020	86	82	520	520	1129						
15	ER2M150S-L	1310	1230	1020			102	77						1305
20	ER2M200S-L	1345												

# ER2SG Large Capacity

With Geared Trolley

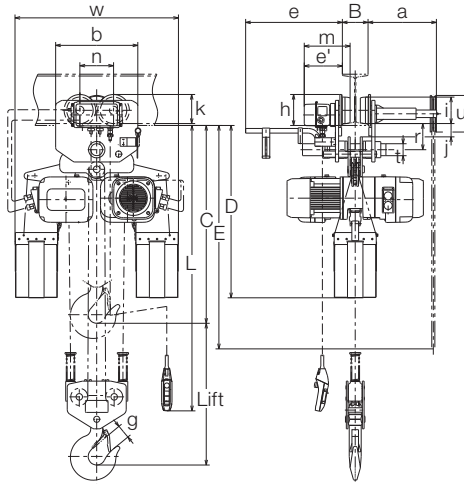

- Ten meters of power supply cable as standard accompanies.
- Optional length of lift, push button cord and power supply cable besides standard is available on your request.
- Extending the load chain is prohibited with additional links.
- Steel chain containers are available as option as shown in Section of "Chain Containers" if your lift is more than capacity of the standard container volume.

## Specifications

Capacity (t)	Product Code	ER2							TSG					Test Load (t)	Net Weight (kg)	Additional Weight per 1m Lift (kg)	
		Hoist Body	Standard Lift (m)	Push Button Cord L (m)	Lifting Motor		Lifting Speed (m/min)		Load Chain Diameter x Chain Falls	Classification ISO/FEM /ASME	Folded Hand Chain Length E (m)	Flange Width B (mm)					Min. Radius Curve (mm)
					Output (kW)	Rating (%ED)	50Hz	60Hz				Standard	Option W30 (305mm)				
7.5	ER2SG075S				3.5		1.9	2.3	11.2 x 3					9.4	275	9.3	
10	ER2SG100L	F	3	3.3	60	1.4	1.7	11.2 x 4	M4/1Am /H4	3.2	150 to 220	221 to 305	3000	12.5	370	12	
	ER2SG100S					2.9	3.5								395		
15	ER2SG150S				3.5x2		1.9	2.3	11.2 x 6					18.8	563	19	
20	ER2SG200S						1.4	1.7	11.2 x 8				∞	25	621	24	

Note: Trolley wheels for tapered I-beam are provided as standard. The wheels for flat flange beam are also available so make a request in advance if necessary.

## Dimensions (mm)

Capacity (t)	Product Code	Headroom C	D	a	b	e	e'	g	h	i	j	k	m	n	r	t	u	w
7.5	ER2SG075S	1165	1230					61			87							662
10	ER2SG100L	1180	1210	372	480			80			77			196.5				718
	ER2SG100S		1020		531		185	155	77	171		269						956
15	ER2SG150S	1310	1230	1012	1000		223	86			82							1129
20	ER2SG200S	1345	1230	1012	1000			102			77			520				1305

# TWER2M Twin Hook



KITO Twin Hook electric chain hoist, which is equipped with a single motor and two hooks, is intended to lift the hooks horizontally, equally and safely. This product is the most suitable for lifting applications requiring two lifting points for a wide load or retaining a level lifting. For special requirements such as dual speed or curve beam, consult with the nearest KITO dealer.

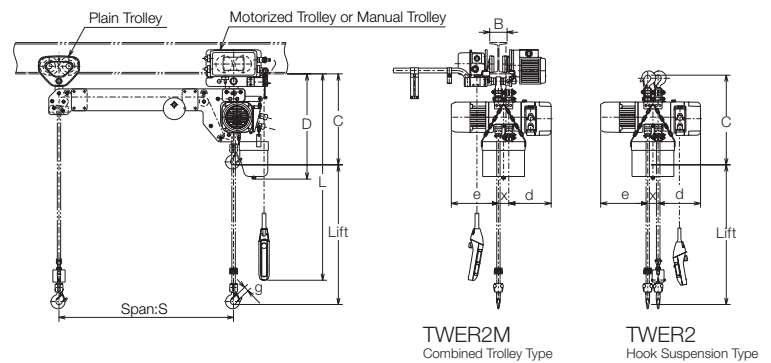

## Specifications

Capacity (t)	Product Code	Hoist Body	Standard Lift (m)	Push Button Cord L (m)	ER2				Trolley					Test Load (t)	
					Lifting Motor		Lifting Speed (m/min)		Load Chain Diameter (mm) x Chain Falls	Traversing Motor		Traversing Speed (m/min)			Flange Width B (mm)
					Output (kW)	Rating (%ED)	50Hz	60Hz		Output (kW)	Rating (%ED)	50Hz	60Hz		
125kg + 125kg	TWER2M003S	C			0.56	60	9.2	11.0	6 x 2	0.4	40	20 (10)	24 (12)	58 to 153	156kg x 2
250kg + 250kg	TWER2M005L						3.8	4.6							7.3
	TWER2M005S	D	3	2.5	0.9	60	3.5	4.2	7.7 x 2	40	20 (10)	24 (12)	58 to 153	625kg x 2	
500kg + 500kg	TWER2M010L						7.1	8.5							10.2 x 2
	TWER2M010S	E			1.8	60	3.7	4.4	10.2 x 2	40	20 (10)	24 (12)	82 to 178	1.25 x 2	
1 + 1	TWER2M020L						E								
	TWER2M020S	F				60			4.4	5.3	10.2 x 4	0.75			
1.5 + 1.5	TWER2M030S						F								60
2.5 + 2.5	TWER2M050S					60					2.9	3.5	11.2 x 4	0.75	

Note: The bracketed figures in Traversing Speed are low speed. This product is designed for straight beams. Specify a beam width at the time of quotation or order.

The following information will be provided upon your request: 1) precise weight depending on length of the hook span 2) availability of curve beams 3) availability of a lift exceeding the maximum (8m)

## Dimensions (mm)

Capacity (t)	Product Code	Headroom C		D	S	d	e	g	x	
		With Trolley	Hook							
125kg + 125kg	TWER2M003S	535	525	620	Min. 510	242	271	27	60	
250kg + 250kg	TWER2M005L						268			
		TWER2M005S	615	620	710	Min. 530	291	298	31	71
500kg + 500kg	TWER2M010L	307								
		TWER2M010S	800	830	790	Min. 650	308	338	39	81
1 + 1	TWER2M020L	347						356		
	TWER2M020S	970	995	920					44	85
1.5 + 1.5	TWER2M030S									
2.5 + 2.5	TWER2M050S	1020	1025	990					47	85

Note: Maximum hook span (S) is 4m. Longer span is also available so contact the nearest KITO dealer.



# SHER2M Ultra Low Headroom



KITO Ultra Low Headroom electric chain hoist is uniquely designed to have a shorter headroom than that of standard ER2 configurations. This product is the most suitable for installation which requires a low ceiling of buildings or maximizes effective lift. The trolleys are available as option. For special requirements such as rated capacity over 10t, dual speed or curve beam, consult with the nearest KITO dealer.

## Headroom Comparison

Capacity (t)	Code	Headroom C (mm)		
		Ultra Low Headroom	Standard ER2M	Difference
250kg	003S	265	375	-110
500kg	005L	285	395	-110
	005S			
1	010L	345	435	-90
	010S			
1.5	015S	435	505	-70
2	020L	475	570	-135
	020S		585	-110
3	030S	610	765	-155
5	050S	670	900	-230

## Load Factor & Number of Starts for replacement

Load chain periodical replacement is recommended for breakage prevention

Load Factor	100%	75%	50%	25%
Number of Starts	20,000	60,000	200,000	400,000

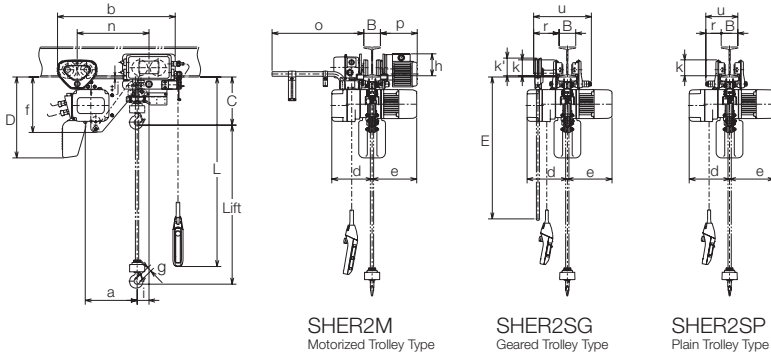

## Specifications

Capacity (t)	Product Code	Hoist Body	ER2										Traversing Motor	Trolley		Test Load (t)	Net Weight (kg)		
			Standard Lift (m)	Push Button Cord L (m)	Lifting Motor		Lifting Speed (m/min)		Load Chain	Output (kW)	Rating (%ED)	Traversing Speed (m/min)		Flange Width B (mm)	Motorized Trolley		Geared Trolley	Plain Trolley	
					Output (kW)	Rating (%ED)	50Hz	60Hz											Diameter (mm) x Chain Falls
250kg	SHER2M003S	B			0.56		9.2	11.0	4.3 x 1						313kg	78	61	56	
500kg	SHER2M005L	C			0.9	60	3.8	4.6	6 x 1					75 to 125	625kg	84	67	62	
	SHER2M005S						7.3	8.8								90	73	68	
1	SHER2M010L	D	3	2.5	60	60	3.5	4.2	7.7 x 1	0.4	40	20	24	100 to 125	1.25	104	87	82	
	SHER2M010S						7.1	8.5								124	107	102	
1.5	SHER2M015S	E			1.8		4.8	5.8	10.2 x 1					1.88	158	139	134		
2	SHER2M020L	F					3.7	4.4							125 to 150				2.5
	SHER2M020S					5.7	6.8	11.2 x 1	212	193	188								
3	SHER2M030S	E		2.8	3.5		3.5	4.2	10.2 x 2					3.75	241	222	217		
5	SHER2M050S	F					2.9	3.5	11.2 x 2	0.75				6.25	322	307	300		

Note: The bracketed figures in Traversing Speed are low speed. This product is designed for straight beams. Specify a beam width at the time of quotation or order. The following information will be provided upon your request: 1) availability of curve beams 2) availability of a flange width exceeding the maximum.

## Dimensions (mm)

Capacity (t)	Product Code	Headroom C	D	E	a	b	d	e	f	g	h	i	j	k	k'	n	o	p	r	u		
250kg	SHER2M003S	265	430		260	656(616)	219	259	325			68				380						
500kg	SHER2M005L	285	525		310	706(666)	242	271	370			27		70	18	95	107	430	515	220	152(56)	345(249)
	SHER2M005S							268														
1	SHER2M010L	345	550	3700	339	734(694)	291	298	405	31		77				458						
	SHER2M010S							307														
1.5	SHER2M015S	435	640		389	826(803)	308	338	487	34						523						
2	SHER2M020L							39														
	SHER2M020S	475	840		423	846(823)	337	399	527	39						543						
3	SHER2M030S	610	830		435	892(884)	347	356	487	44	131	45	24	134	115	560	521	226	157(79)	398(320)		
5	SHER2M050S	670	860	4200	475	1057(1057)	337	399	542	47	145	66	31	144	131	657	528	281	156(53)	401(297)		

Note: The bracketed figures in Size "b" are for geared or plain trolley. The bracketed figures in Size "r" or "u" are for plain trolley. Size "D" is for a lift of 4m. This information which varies depending on the lift is provided upon your request.

# Options

## Mechanical Brake with Friction Clutch

KITO's own device combining functions of friction clutch and mechanical brake for the capacities of 10 t L or less, which requires additional components. (Request at placing an order of the hoists)



## Overload Limiter

For additional security, Overload Limiter (OLL) is recommended as an option which is preset by 115% of rated capacity. OLL protects the hoist mechanism from damage under overload conditions. (a load can be lowered even after OLL sets off.)

Standard setting: 115% of rated capacity

Adjustable setting: from 90%-135% of rated capacity

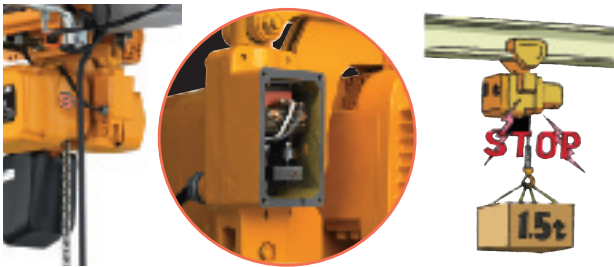

## Drop Stops

Provides additional security of the motorized trolley for the operator and the equipment.

## Rubber Bumpers

Provides protection of the motorized trolley from collisions.

## Load Bell

KITO Load Bell has accuracy of alerting you when your hoist is overloaded. This bell helps increase the safety and efficiency of your operations with economical cost.



### Extra headroom & weight with KITO Load Bell

Rated capacity (t)	Load chain diameter x chain fall (mm)	Extra headroom (mm)	Weight (kg)
500kg	6.0x1	171	3
1	7.7x1	189	4
1.5	10.2x1	227	5
2	11.2x1	124	8
2.5	11.2x1	121	8
3	10.2x2	113	10

Setting: 100-110 % of rated capacity

Power supply: DC 9V (9V dry battery)

Service life of battery: 700H in intermittent use (4hr per day)

Alerting buzzer volume: Min. 85dB

Enclosure: IP55

# Hook Dimensions

Product Code	Top Hook (mm)						Bottom Hook (mm)					
	D	g	i	j	k	l	D	g	h	f	e	c
ER2-001H/IH												
ER2-003S/IS												
ER2-003H/IH	35.5	27.0	17.5	23.5	28.0	17.5	35.5	27.0	17.5	23.5	28.0	17.5
ER2-005L/IL												
ER2-005S/IS												
ER2-010L/IL	42.5	31.0	22.5	31.0	36.5	22.5	42.5	31.0	22.5	31.0	36.5	22.5
ER2-010S/IS												
ER2-015S/IS							47.5	34.0	26.5	36.5	43.5	26.5
ER2-020L/IL	53.0	39.0	31.5	43.5	51.5	31.5						
ER2-020S/IS							53.0	39.0	31.5	43.5	51.5	31.5
ER2-025S/IS			32.5	44.0	52.0	32.5						
ER2-030S/IS	60.0	44.0	34.5	47.5	56.0	34.5	60.0	44.0	34.5	47.5	56.0	34.5
ER2-050S/IS	63.0	47.0	42.5	56.0	67.0	42.5	63.0	47.0	42.5	56.0	67.0	42.5

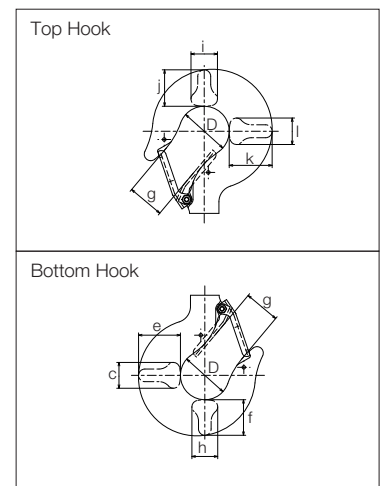



# Applications





**KITO** CORP.



Tokyo Opera City Tower 16th Floor,  
3-20-2 Nishi-Shinjuku, Shinjuku-ku, Tokyo 163-1416, JAPAN  
TEL: +81-3-5371-7315, FAX: +81-3-5371-7349  
E-mail: [overseas@kito.co.jp](mailto:overseas@kito.co.jp)  
URL: <http://www.kito.co.jp>

## **International Sales Subsidiaries**

### **U.S.A.**

#### **HARRINGTON HOISTS, INC.**

401 West End Avenue, Manheim, PA 17545, U.S.A.  
TEL: +1 717-665-2000 FAX: +1 717-665-2861  
URL: <http://www.harringtonhoists.com>

### **CANADA**

#### **KITO CANADA INC.**

309-3815 1st. Avenue, Burnaby, BC, V5C 3V6, CANADA  
TEL: +1 604-291-9955 FAX: +1 604-294-8855  
E-mail: [info@kito.ca](mailto:info@kito.ca)  
URL: <http://www.kito.ca>

### **GERMANY**

#### **KITO EUROPE GmbH**

Heerdter Lohweg 93, D-40549 Düsseldorf, GERMANY  
TEL: +49-(0)211-528009-00 FAX: +49-(0)211-528009-59  
E-mail: [info@kito.net](mailto:info@kito.net)  
URL: <http://www.kito.net>

### **CHINA**

#### **JIANGYIN KITO CRANE CO., LTD.**

18 Cheng Jiang East Road, Jiang Yin, Jiang Su 214429, CHINA  
TEL: +86-510-86199666 FAX: +86-510-86196633  
URL: <http://www.kaicheng.com>

#### **SHANGHAI KITO TRADING CO., LTD.**

Room#2205, Ascendas Plaza, 333 Tian Yao Qiao Road, Shanghai, 200030, CHINA  
TEL: +86 21-54488935 FAX: +86 21-54488937  
URL: <http://www.kito.com.cn/>

### **THAILAND**

#### **SIAM KITO CO., LTD.**

700/243 M.1, Amatanakorn Industrial Estate Phase 2,  
Bangna-Trad KM.57, T.Bankao, A.Panthong, Chonburi 20160, THAILAND  
TEL: +66-3846-8205 FAX: +66-3846-8195  
URL: <http://www.siamkito.co.th/>

Distributed by: